

**GOODWE**



# **User manual**

**Charger (AC)**

HCA series  
(7–22 kW) G2

V1.3-2025-07-03

**Copyright©GoodWe Technologies Co., Ltd. 2025. All rights reserved.**

No part of this manual may be reproduced or transmitted to a public platform in any form or by any means without the prior written consent of GoodWe.

### **Trademarks**

**GOODWE** and other GoodWe trademarks are trademarks of GoodWe Company. All other trademarks or registered trademarks mentioned in this manual are the property of GoodWe.

### **NOTICE**

The information in this user manual is subject to change due to product updates or other reasons. Unless otherwise stated, this manual cannot replace the safety instructions or labels on the device.

# CONTENTS

<b>1</b>	<b>About this manual</b> .....	<b>1</b>
1.1	Applicable model .....	1
1.2	Target audience .....	1
1.3	Definition of symbols .....	2
<b>2</b>	<b>Safety precautions</b> .....	<b>3</b>
2.1	General safety .....	3
2.2	Charger safety (AC) .....	3
2.3	Requirements for personnel .....	4
2.4	Declaration of conformity .....	5
<b>3</b>	<b>Product overview</b> .....	<b>6</b>
3.1	Product overview .....	6
3.2	Application scenarios .....	7
3.3	Charging mode .....	9
3.4	Charger operating status .....	10
3.5	Functions .....	10
3.6	Appearance .....	12
3.6.1	Component description .....	12
3.6.2	Dimensions .....	14
3.6.3	Description of indicator lights .....	16
3.6.4	Manufacturer's label .....	16
<b>4</b>	<b>Inspection and storage</b> .....	<b>17</b>
4.1	Inspection prior to acceptance .....	17
4.2	Deliveries .....	17
4.3	Storage .....	18
<b>5</b>	<b>Installation</b> .....	<b>19</b>
5.1	Installation requirements .....	19
5.2	Installation .....	21
5.2.1	Moving the charger .....	21
5.2.2	Installing the charger (on the wall) .....	22
5.2.3	Installing the charger (on a post) .....	23
5.2.4	Installation of MID meter (optional) .....	24
<b>6</b>	<b>Electrical connection</b> .....	<b>25</b>
6.1	Safety precautions .....	25
6.2	Connecting the RCD cable .....	27
6.3	Connecting the power cable (AC) .....	28
6.4	Connecting the communication cable .....	29
6.4.1	Connecting the RS485 communication cable .....	29
6.4.2	Connecting the LAN communication cable .....	30
6.4.3	Connecting the MID meter cable (optional) .....	30

<b>7</b>	<b>Commissioning the device</b> .....	<b>31</b>
	7.1 Checks before switching on the power supply .....	31
	7.2 Switching on the power supply.....	31
	7.3 Charging the EV.....	32
	7.3.1 Starting charging via the SolarGo app or SEMS Portal .....	32
	7.3.2 Charging scheduling via the SolarGo app or the SEMS portal .....	33
	7.3.3 AUTO Start mode .....	34
	7.3.4 Charging an RFID card .....	34
<b>8</b>	<b>Commissioning the system</b> .....	<b>35</b>
	8.1 Indicator .....	35
	8.2 Setting up and checking charger information using the SolarGo app (installation personnel) .....	35
	8.2.1 Downloading and installing the app.....	35
	8.2.2 Log in to the charger.....	36
	8.2.3 Introduction to the home page.....	37
	8.2.4 WiFi configuration .....	38
	8.2.5 Charging Mode Configuration.....	39
	8.2.6 More .....	41
	8.3 Setting and checking charger information via the app SEMS Portal APP (installers).....	44
	8.3.1 Downloading and installing the app.....	44
	8.3.2 Registering an end-user account .....	44
	8.3.3 Logging in to the app.....	45
	8.3.4 Creating a device.....	46
	8.3.5 Configuring charging mode.....	47
	8.3.6 Settings .....	50
<b>9</b>	<b>Maintenance</b> .....	<b>54</b>
	9.1 Switching off the charger.....	54
	9.2 Dismantling the charger .....	54
	9.3 Disposing of the charger.....	54
	9.4 Routine maintenance.....	54
	9.5 Troubleshooting .....	55
<b>10</b>	<b>Technical specifications</b> .....	<b>57</b>



# 1 About this manual

This manual provides information on the product, installation, electrical connection, commissioning, troubleshooting and maintenance of the charger. Please read this manual before installing and operating the product. All installers and users must be familiar with the product's features, functions and safety precautions. This manual may be updated without prior notice. For further product details and the latest documents, please visit <https://en.goodwe.com/>.

## 1.1 Applicable model

This manual applies to the chargers listed below: (Hereinafter referred to as HCA).





- GW7K-HCA-20
- GW11K-HCA-20
- GW22K-HCA-20

## 1.2 Target

This manual is intended solely for trained and knowledgeable technical personnel. Technical personnel must be familiar with the product, local standards and electrical systems.

## 1.3 Definition of symbols

The various levels of warning messages in this manual are defined as follows:

Indicates a high-level hazard which, if not avoided, will result in death or serious injury.

Indicates a medium-level hazard which, if not avoided, may result in death or serious injury.

Indicates a low-level hazard which, if not avoided, may result in minor or moderate injury.

Highlight and add to the text. Or include some time-saving skills and methods for solving problems related to the product.



## 2 Safety measures

Strictly follow these safety instructions in the user manual during operation.

### WARNING

The charger has been designed and tested in accordance with relevant safety regulations. Before carrying out any operations, read and follow all safety instructions and warnings. Incorrect operation could result in personal injury or damage to property, as chargers are electrical devices.

### 2.1 General safety

#### WARNING

- The information in this user manual may change due to product updates or for other reasons. Unless otherwise stated, this manual cannot replace the labels on the product or the safety precautions in the user manual. All descriptions in the manual are for guidance only.
- Read the user manual before installation to familiarise yourself with the product and safety precautions.
- All installations must be carried out by trained and qualified technicians who are familiar with local standards and safety regulations.
- When operating the charger, use insulated tools and wear personal protective equipment to ensure personal safety. When handling electronic equipment, use antistatic gloves, wipes and wrist straps to protect the charger from damage.
- Strictly follow the installation, operation and configuration instructions provided in this manual. The manufacturer accepts no liability for damage to equipment or personal injury resulting from failure to follow the instructions. For further information on the warranty, please visit: <https://en.goodwe.com/warranty>.

### 2.2 Charger safety (- current)

#### DANGER









- Do not dismantle the charger modules yourself. Do not use an extension lead with the charging cable. Failure to do so may reduce the protection against the ingress of foreign objects or liquids, or a risk of electric shock.
- The device supports only the charging of electric vehicles (hereinafter referred to as EVs). Do not use it to charge other devices.
- After using the charging connector, cover the charging plug properly and wrap the charging cable around the charger.
- Do not bend, crush or twist the charger or cables excessively. Failure to do so may result in damage to the device.
- Before starting installation, maintenance or other activities, disconnect the charger and any switches connected upstream of it.
- It is strictly forbidden to touch the charging connector whilst the charger is live.

#### WARNING

Check regularly that the cover and charger look in good condition.

**! DANGER**

- All labels and warning signs should be visible after installation. Do not cover, alter or damage any labels on the device.
- The following warning labels are on the charger:

	<p>DANGER: HIGH HIGH VOLTAGE There is high voltage in the charger. Disconnect all power supplies and switch off the unit before working on it.</p>		<p>Delayed discharge. After switching off the power, wait 5 minutes until the components have fully discharged.</p>
	<p>Read the operating instructions before carrying out any operations.</p>		<p>There are potential risks. Use appropriate personal protective equipment before carrying out any operations.</p>
	<p>Risk of high temperature. Do not touch the product whilst it is in operation to avoid burns.</p>		<p>Do not dispose of the charger as household waste. Dispose of the product in accordance with local laws and regulations, or return it to the manufacturer.</p>
	<p>CE mark.</p>		<p>RCM mark.</p>
	<p>ANATEL marking.</p>		

### 2.3 e requirements

**WARNING**

- Personnel installing or maintaining the equipment must be thoroughly trained and familiar with safety precautions and correct operation.
- Installation, operation, maintenance and replacement of the equipment or its parts must only be carried out by qualified experts or trained personnel.



## 2.4 Declaration of Conformity

### EU

Products with wireless communication functions sold on the European market comply with the requirements of the following directives:

- Radio Equipment Directive 2014/53/EU (RED)
- Directives 2011/65/EU and (EU) 2015/863 on the restriction of the use of certain hazardous substances (RoHS)

### United Kingdom

A product with wireless communication capabilities sold on the UK market complies with the requirements of the following directives:

- The Radio Equipment Regulations 2017
- Restriction of the use of certain hazardous substances as set out in the Electrical and Electronic Equipment Regulations 2012 (S.I. 2012/3032)

### Brazil

The product with wireless communication functionality sold on the Brazilian market complies with the requirements of the following directives:

- The product is certified by Anatel under number 06795-24-02673.
- This equipment is not protected against harmful interference and must not cause interference to systems that are duly authorised. Further information can be found on the ANATEL website [www.gov.br/anatel/pt-br](http://www.gov.br/anatel/pt-br).

### NOTICE

- 2.4G WiFi, operating frequency: 2412-2472 MHz, max e.i.r.p: 18.99 dBm
- BLE 1M & 2M, operating frequency: 2402-2480 MHz, max. e.i.r.p.: 2.99 dBm
- RFID 13.56 MHz, max. ERP: -47.50 dBm

## 3 product overview

### 3.1 product overview

The HCA series product is an AC home charger designed primarily for charging electric vehicles. It can communicate with an inverter and utilise photovoltaic energy to charge electric vehicles, retrieve data from smart meters via the inverter for dynamic load management, communicate with a MID meter (MID-certified smart meter) and provide billing statements. It supports activation via an RFID card, activation via an app, and automatic activation upon connection of the charging plug. It also supports overcharge protection, grid monitoring, etc.

#### Model

This manual applies to the chargers listed below:

- GW7K-HCA-20
- GW11K-HCA-20
- GW22K-HCA-20

#### Model description

SEMS Portal application

#### GW11K-HCA-20



No.	See	Explanation
1	Brand code	GW: GoodWe
2	Rated power	<ul style="list-style-type: none"> <li>• 7K: the rated output power is 7 kW.</li> <li>• 11K: the rated output power is 11 kW.</li> <li>• 22K: the rated output power is 22 kW.</li> </ul>
3	Series	HCA: HCA series
4	Generation	20: second generation.



### 3.2 nd application scenarios

#### With PV and battery

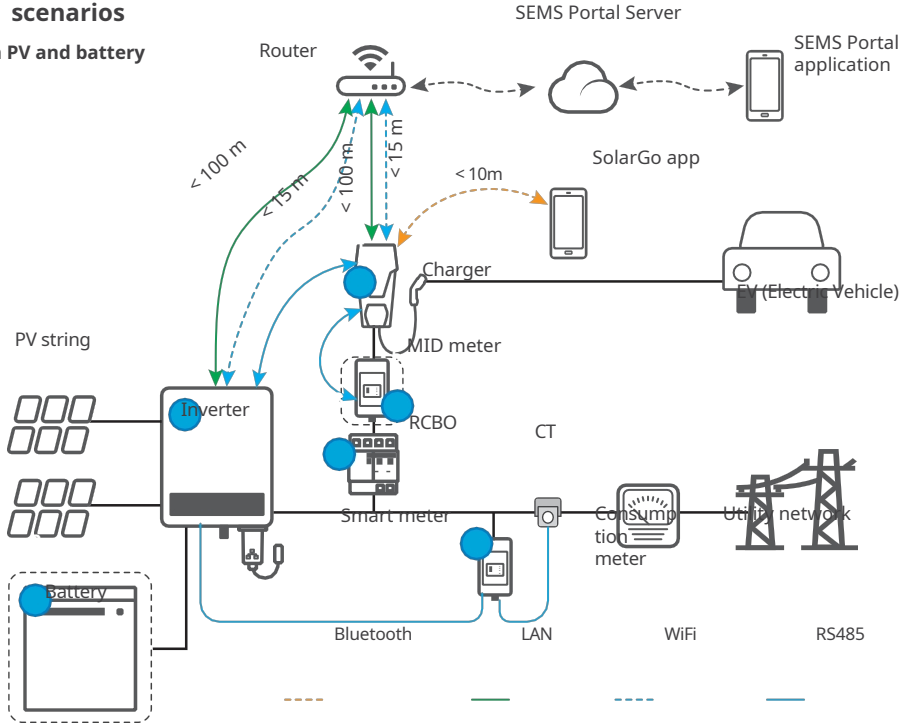

#### Without PV or battery

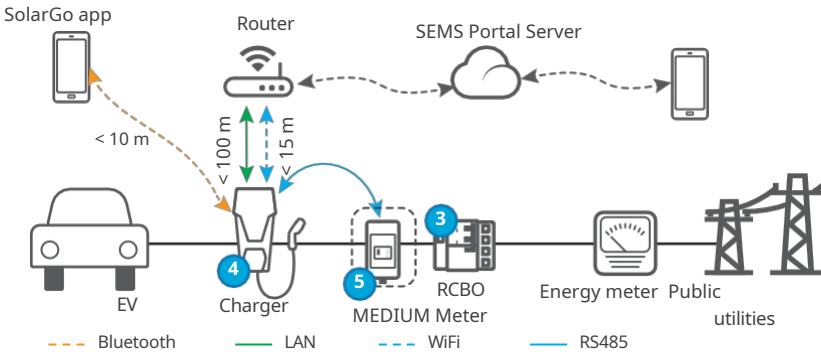

No.	Parts	Description
1	Inverter	GoodWe grid-connected photovoltaic inverters and hybrid inverters.
2	Batteries	Batteries compatible with GoodWe hybrid inverters.
3	RCBO	Provides residual current protection and overcurrent protection for the charger. To purchase the device, please contact the charger manufacturer.
4	Charger	GoodWe HCA series charger.
5	MEDIUM Meter	Collects energy consumption data from the electric vehicle charger, which can be used to settle bills.
6	Smart meter	Supplied with the inverter or purchased from the inverter manufacturer.

### Wiring diagram

The wiring diagram for the HCA charger is shown below:

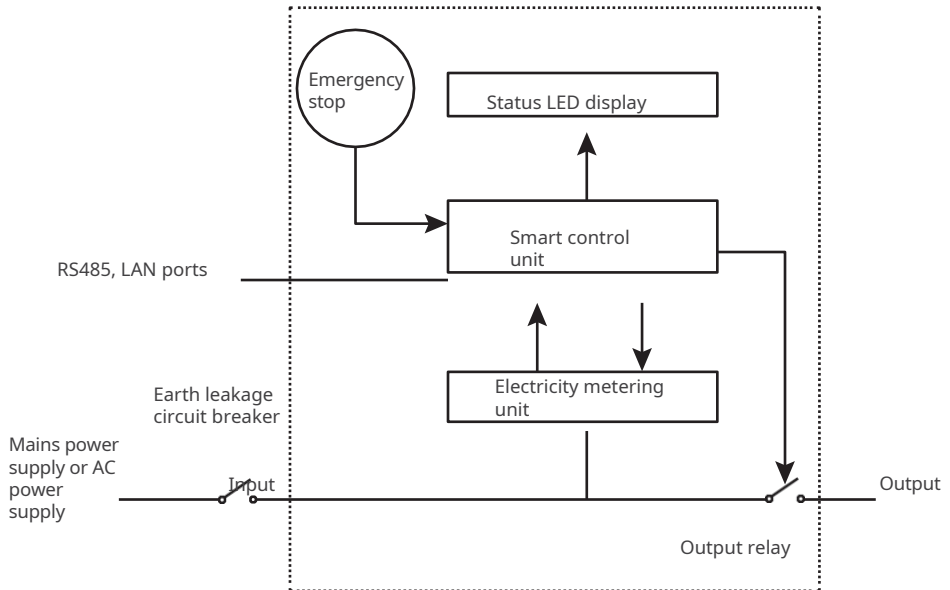

- The RS485 port is used for communication with photovoltaic inverters or MID meters.
- The LAN port is used for communication with a router.
- For single-phase AC chargers and three-phase AC chargers, the input port is used to connect a single-phase three-core mains supply cable or a three-phase five-core mains supply cable, respectively.
- The output port is used to connect to the charging plug.
- Emergency stop refers to the emergency stop button.



## Mains types

Single-phase scenario:

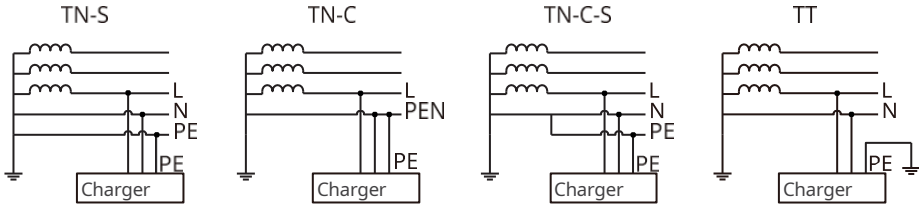

Three-phase scenario:

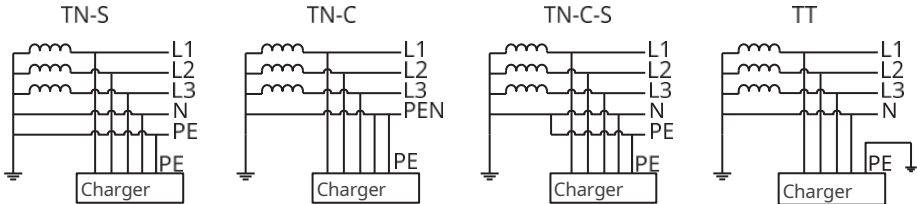

## 3.3 e charging mode

### NOTICE

In PV Priority and PV + Battery modes, the charging power of the EV charger is limited by the maximum output power of the inverter.

### Fast

The charger uses electricity from the mains, photovoltaics or batteries to charge electric vehicles. The charger's output power is set by default to the charger's rated output power, and users can set the output power to a value no higher than the rated output power.

### PV priority

Only photovoltaic energy is used to charge the electric vehicle. Loads, which may be grid loads or backup loads, take priority in consuming energy from the photovoltaic system; the remaining energy will be used to charge the electric vehicle.

### PV + Battery

Photovoltaic energy and the battery are used to charge the electric vehicle. Load The load, which may be a grid load or a backup load, takes priority in energy consumption; the remaining energy will charge the electric vehicle.

### 3.4 nd charger operating status

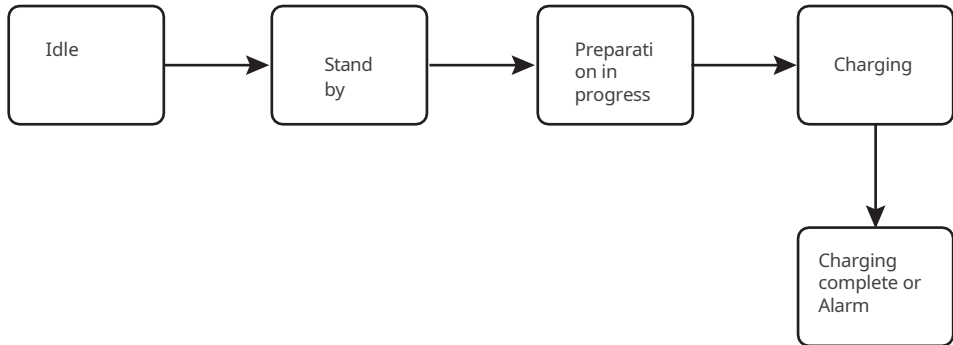

### 3.5 Function

#### NOTICE

- The maximum charging power of the charger is limited by the maximum charging power of the vehicle's on-board charger (OBC).
- The minimum inrush current for each phase of the charger is 6 A. For single-phase charging, the minimum charging power is 1.4 kW, and for three-phase charging, it is 4.2 kW.
- Three-phase chargers support single-phase, two-phase and three-phase charging, but the actual charging power is influenced by the OBC. When a three-phase charger is charging a vehicle that only supports single-phase charging, its maximum charging power is 1/3 of the charger's rated output power. If a three-phase charger is charging a vehicle that only supports two-phase charging, its maximum charging power is 2/3 of the charger's rated output power

#### Dynamic load control

Once dynamic load control is enabled, the charger will adjust the charging rate (or even pause charging) based on data obtained from the meter and the set grid connection current to prevent the main fuse from tripping. If the actual current drawn approaches the set mains connection current, the charger will reduce the charging power and interrupt charging to prevent a trip. The charger will automatically restart once the difference between the set mains connection current and the current drawn from the mains meets the charger's start-up conditions.

#### Ensuring minimum charging power

If the energy from the PV system or the PV + battery system is insufficient, the charger can draw support from the grid or the battery to maintain the required power output, provided the Minimum Charging Power Guarantee function is enabled. This function is only available in PV Priority or PV + Battery modes. Users can enable the function via the SolarGo app or the SEMS app.



Status	Explanation
Enabled	Continue charging using both mains and battery power to ensure the minimum power required for charging (1.4 kW for 7 kW chargers, 4.2 kW for 11/22 kW chargers).
OFF	Stop charging if there is no longer any surplus from the solar panels.

### Phase switch

#### WARNING

The phase switching function is only available for three-phase chargers.

Status	Explanation
On	If the total power consumption is less than 4.2 kW, the charger automatically switches to single-phase charging mode to prevent drawing power from the grid or the charger switching off. The minimum charging power in single-phase charging mode is 1.4 kW. (The phase switching time is approximately 3 minutes)
OFF	The charger remains in three-phase charging mode.

### Safe and reliable

- The charger's ingress protection rating is IP66 and the charging plug's ingress protection rating is IP55. The high-rated charger has excellent dustproof and waterproof properties and can be installed and maintained outdoors.
- To protect the product and ensure safe operation, the product is equipped with overvoltage and undervoltage protection, overload protection, short-circuit protection, leakage protection, earthing, overheating protection, EMS protection and lightning protection.

### 3.6 Appearance

#### 3.6.1 s description

**Charger**

**Type one**

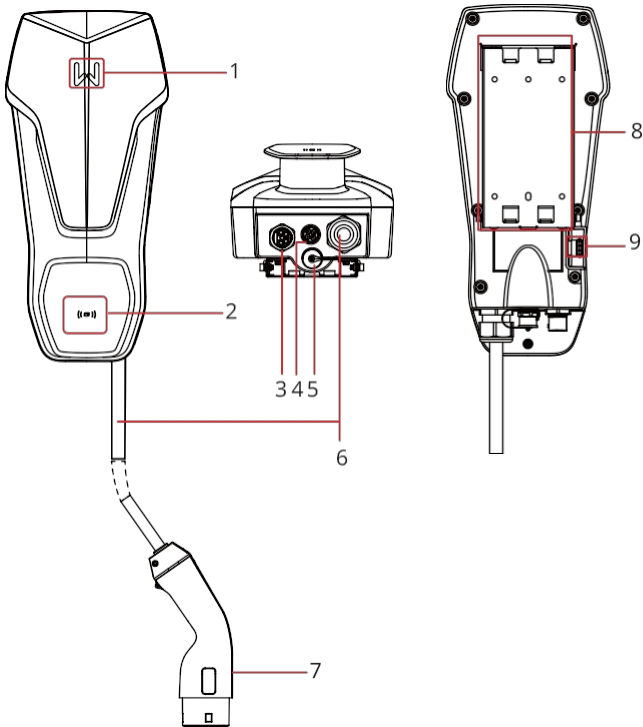

## Type two

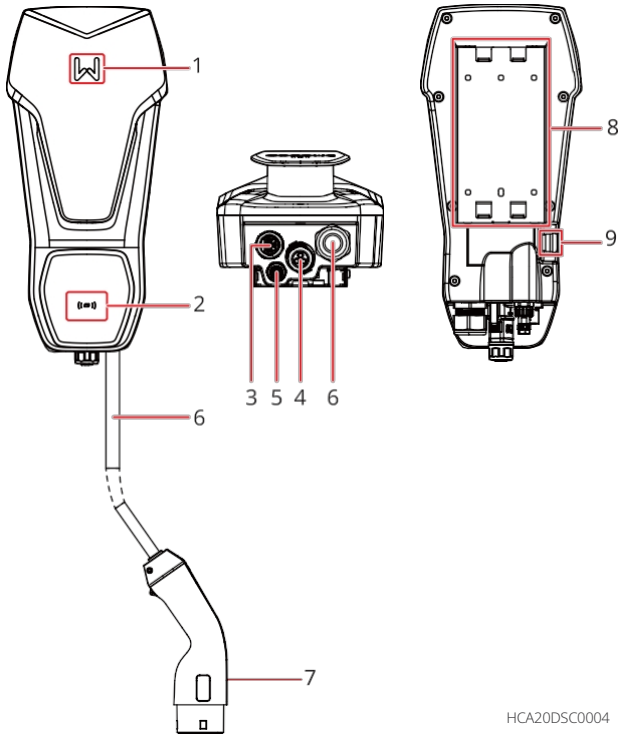

HCA20DSC0004

Part No.	Parts	Description
1	Indicator light	Indicates the charger's operating status.
2	RFID card area	Tap the card to start charging.
3	Power cable input port (AC)	Used to connect a single-phase or three-phase input cable (AC).
4	RS485 communication port	Connects the RS485 communication cable of the inverter or meter.
5	LAN communication port	Connects the router's communication cable.
6	Charging cable	-
7	Charging plug	Plugs into the EV charging port.
8	Mounting plate	Secures the charger to the mounting surface.
9	Emergency stop button	Used for protection in an emergency.

**(optional) Distribution board**

**GW7K-HCA-20**

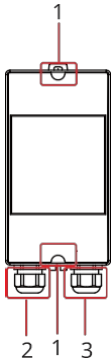

**GW11K-HCA-20 and GW22K-HCA-20**

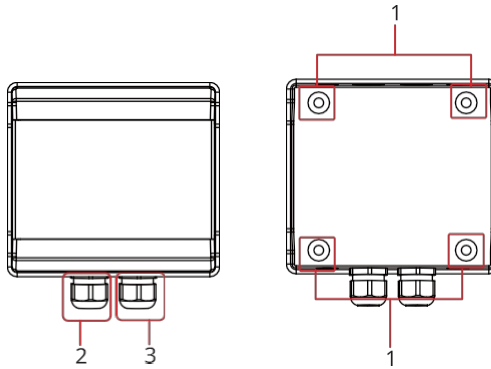

- 1. Mounting holes
- 2. Input port for network cable
- 3. Output port for network cable

**(Optional) Contribution**

**GW7K-HCA-20**

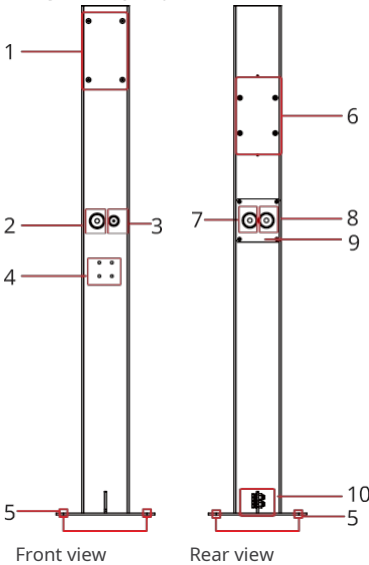

**GW11K-HCA-20 and GW22K-HCA-20**

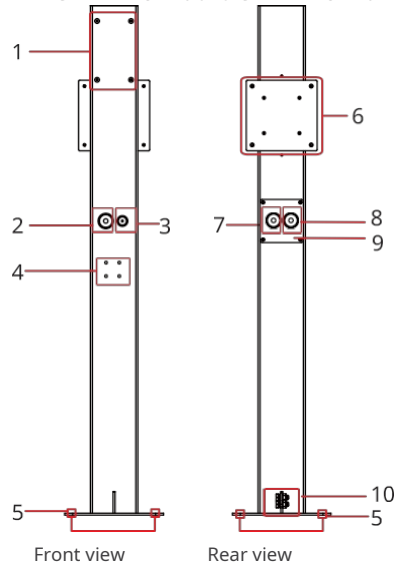

- 1. Charger mounting position
- 2. Mains cable between the RCBO and the charger
- 3. Communication cable port
- 4. Installation position of the dummy socket
- 5. Position of the hole for securing the base
- 6. RCBO installation position
- 7. RCBO AC input cable
- 8. Mains cable between the RCBO and the charger
- 9. Control panel
- 10. PE port

### 3.6.2 Dimensions

#### Charger

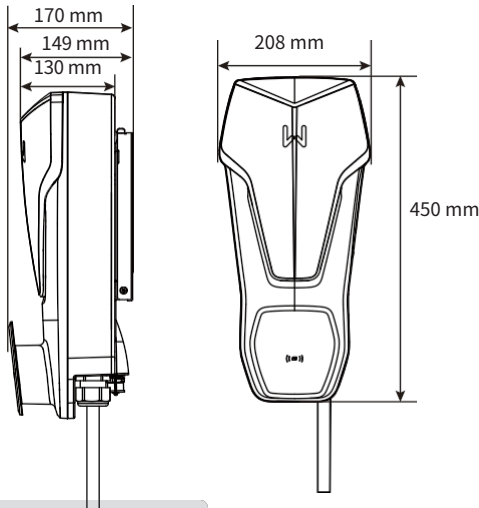

#### (Optional) RCBO distribution board

#### GW7K-HCA-20

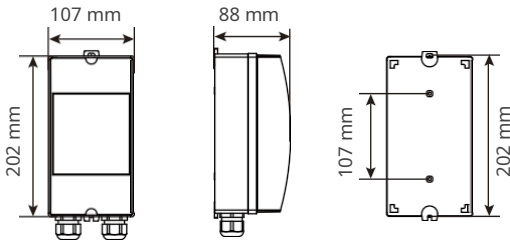

#### GW11K-HCA-20 and GW22K-HCA-20

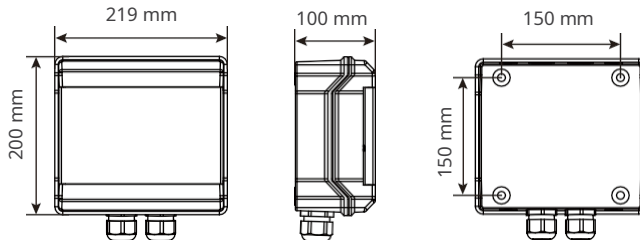

**(Optional) Contribution**

**GW7K-HCA-20**

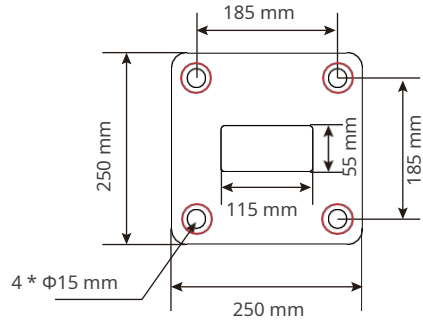
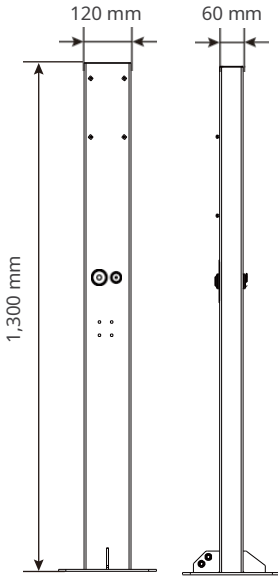

Bottom view of the post

**GW11K-HCA-20 and GW22K-HCA-20**

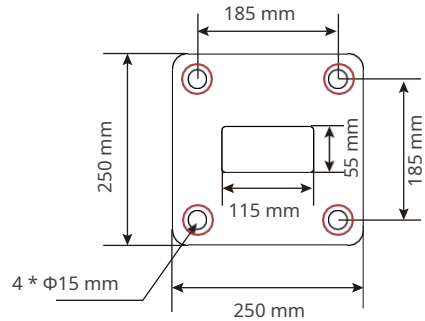
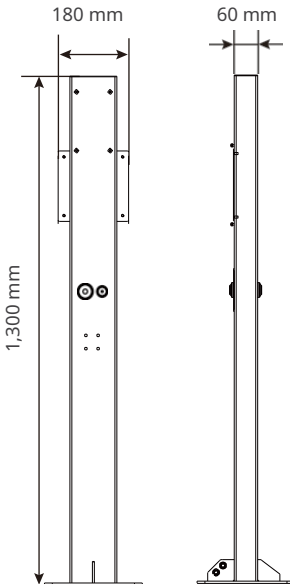

View of the post from below



**(Optional) MID meter**

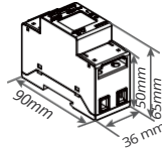
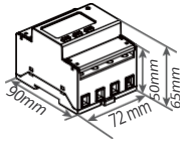

**3.6.3 Indicator light description**

Indicator light	Colour	Explanation
	Green light	The charger is in standby mode.
	Flashing green	The charger system is being updated.
	Blue light on	The charger is charging.
	Red light	A fault has occurred.
	The indicator light status when activating RFID card charging is abnormal	
	The red indicator light comes on for 2 seconds	Tap the card before connecting the charging plug to the electric vehicle.
	The red indicator light flashes twice	The charger and card do not match.

**3.6.4 Manufacturer's label**

The manufacturing label is for reference only.

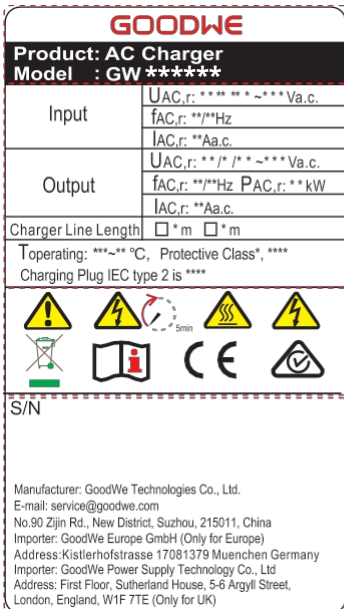

GOODWE brand, product type and product model

Technical specifications

Safety symbols and certification marks

Contact details and serial number

## 4 Inspection and storage

### 4.1 Inspection prior to nd acceptance

Check the following items before accepting the product.

1. Check the outer packaging for damage, such as holes, cracks, deformation and other signs of damage to the device. Do not unpack the packaging and, if damage is found, contact the supplier as soon as possible.
2. Check the charger model. If the charger model does not match your requirements, do not unpack the product and contact the supplier.
3. Check the delivery to ensure it contains the correct model, all components, and is undamaged on the outside. If you find any damage, contact the supplier as soon as possible.

### 4.2 Deliveries



**WARNING**

Connect the cables using the supplied terminals. The manufacturer accepts no liability for damage if other terminals are used.

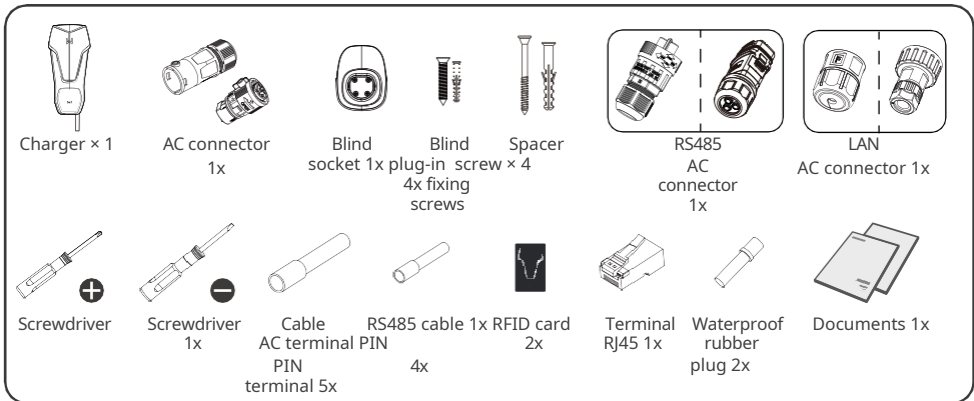

**(Optional) GW7K-HCA-20**

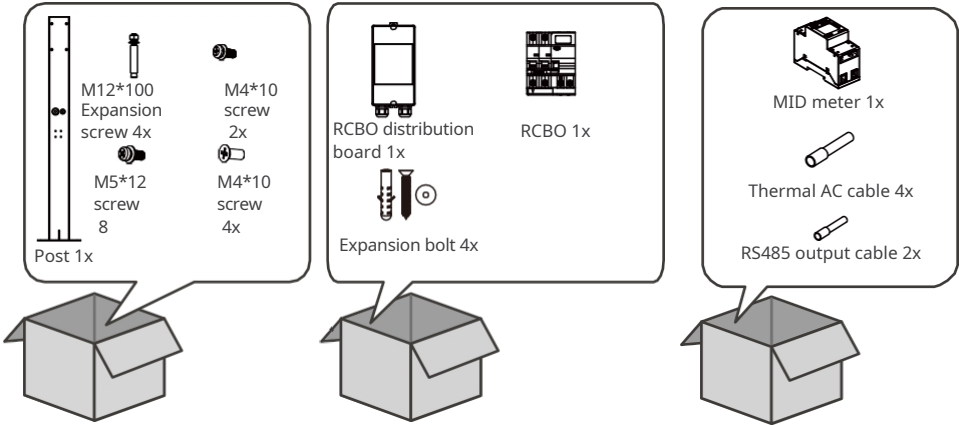

**(Optional) GW11K-HCA-20 and GW22K-HCA-20**

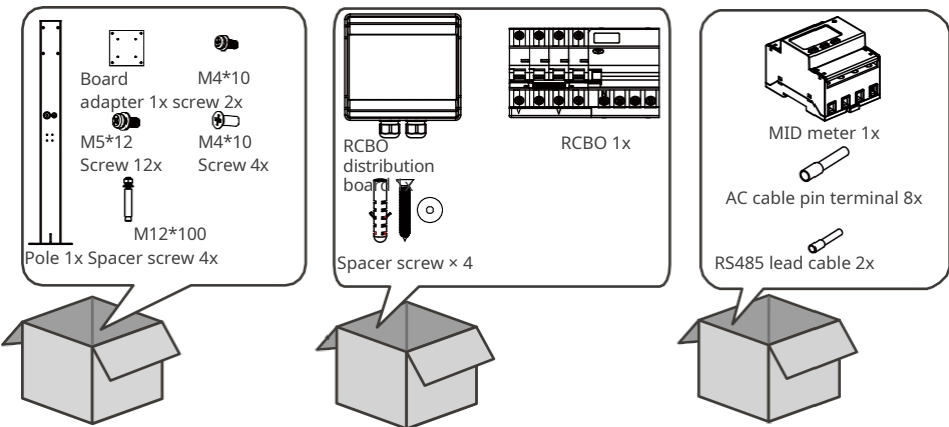

**4.3 Storage**

If you are not going to install or use the charger immediately, ensure that the storage conditions meet the following requirements:

1. Do not remove the outer packaging or discard the desiccant.
2. Store the charger in a clean place. Ensure the location has a suitable temperature and humidity and that condensation does not occur.
3. The height and direction of stacking the chargers should follow the instructions on the packaging.
4. Chargers must be stacked carefully to prevent them from falling.
5. If a charger has been in long-term storage, it should be inspected by specialists before being put into operation.

## 5 Installation

### 5.1 Installation requirements

#### Installation environment requirements

1. Do not install the device near flammable, explosive or corrosive materials.
2. Do not install the device in a location that is easily accessible. The device's temperature rises during operation. Do not touch the surface to avoid burns.
3. When drilling holes, avoid water pipes and cables in the wall.
4. Install the device in a sheltered location.
5. The installation site must be well ventilated to allow for heat dissipation and sufficiently spacious for operation.
6. Devices with a high degree of protection against ingress can be installed indoors or outdoors. The temperature and humidity at the installation site should be within the appropriate range.
7. Install the device at a height suitable for operation and maintenance, electrical connection, and checking indicators and labels.
8. The altitude for installing the charger must be below the maximum operating altitude of 2000 m.
9. Install the device away from electromagnetic interference.

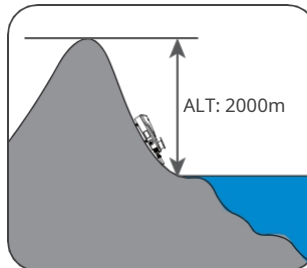
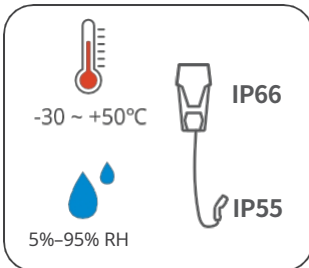
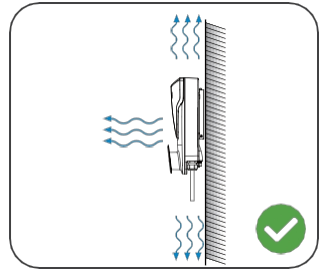
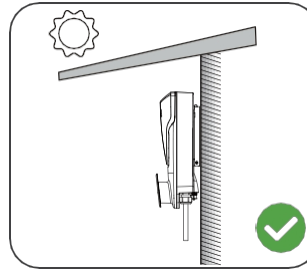
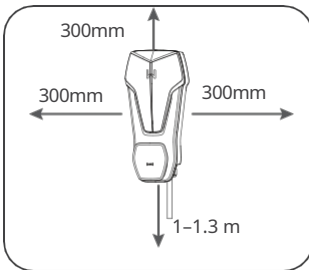
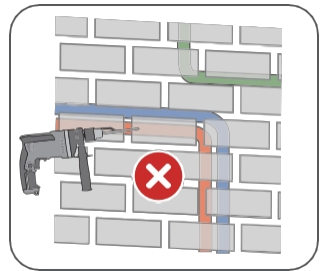
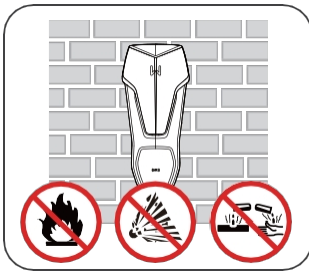



### Requirements for mounting bracket

- The mounting bracket must be non-flammable and fire-resistant.
- Install the charger on a surface that is sufficiently strong to support its weight.

### Installation angle requirements

- It is recommended to install the charger in an upright position.
- Do not install the charger upside down, tilted forwards or backwards, or in a horizontal position.

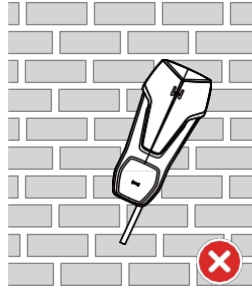
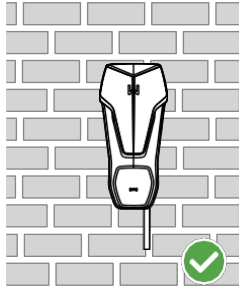
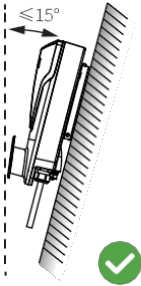

## Requirements for installation tools

It is recommended that you use the following tools when installing the device. If necessary, use additional tools on site.



## 5.2 Installation

### 5.2.1 Moving the nd charger

#### WARNING

Before installation, move the charger to the appropriate location. Follow the instructions below to prevent personal injury or damage to the equipment.

1. Consider the weight of the device before moving it. Ensure there are enough people to move the device to prevent personal injury.
2. Wear protective gloves to prevent personal injury.
3. Keep the device balanced during transport to prevent it from falling.

## 5.2.2 Installing the charger ( nd wall-mounted)

### WARNING

- When drilling holes, avoid water pipes and cables in the wall.
- When drilling holes, wear safety goggles and a dust mask to prevent inhaling dust or getting it in your eyes.
- Make sure the charger is securely installed and cannot fall.

**Step 1** Remove the mounting plate from the charger.

**Step 2** Position the mounting plate, RCBO switchboard and blank socket horizontally on the wall and mark the positions for drilling holes.

**Step 3** Drill the holes using a hammer drill.

**Step 4** Use expansion bolts, the RCBO distribution board and a blank wall socket to secure the mounting plate.

**Step 5** Install the charger onto the mounting plate and secure the mounting plate.

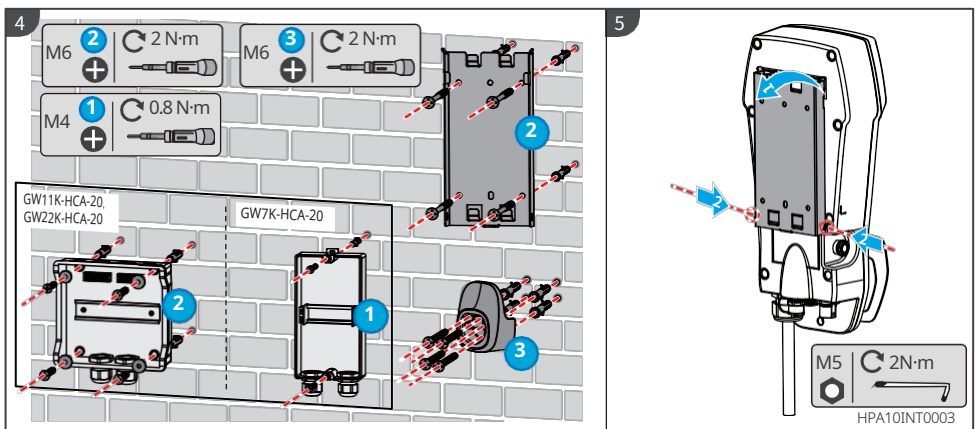
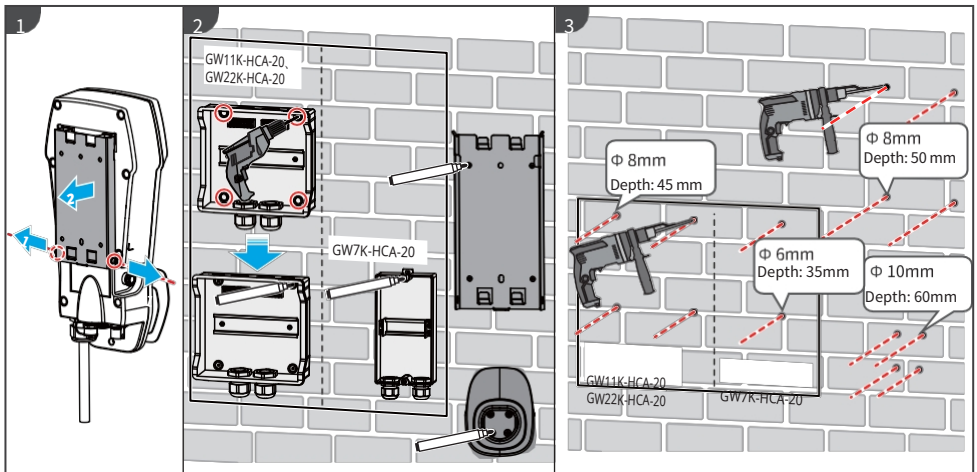

### 5.2.3 Charger installation (on a post)

#### NOTICE

If you need to install the charger on a post, please purchase this post from the manufacturer.

**Step 1** Remove the control panel from the post.

**Step 2** Place the post on the floor in an upright position and mark the positions for drilling the holes. A 60 mm diameter cable gland must be installed underground.

**Step 3** Using a 15 mm hammer drill bit, drill holes to a depth of 75 mm. **Step 4** Feed the recessed cable through the post, use expansion bolts to secure the charger to the ground, and plug the spare fixing holes with screws.

**Step 5** Install the RCBO distribution board and the adapter board onto the post.

**Step 6** Install the blank plug onto the post.

**Step 7** Remove the charger from the mounting plate.

**Step 8** Install the mounting plate onto the post.

**Step 9** Install the charger onto the mounting plate.

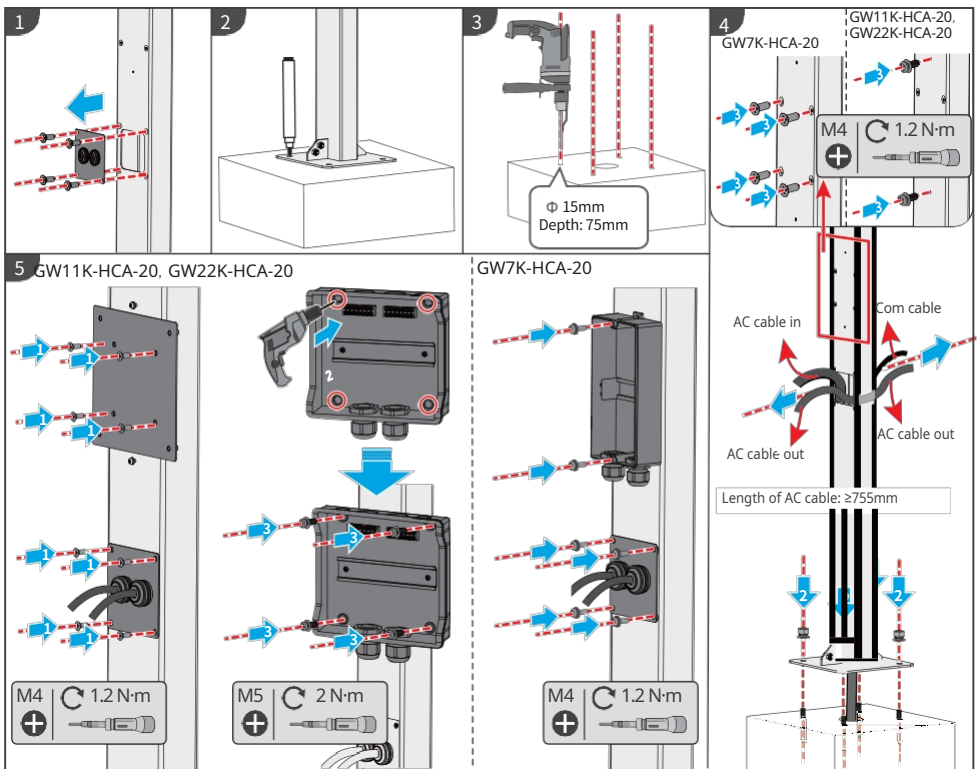

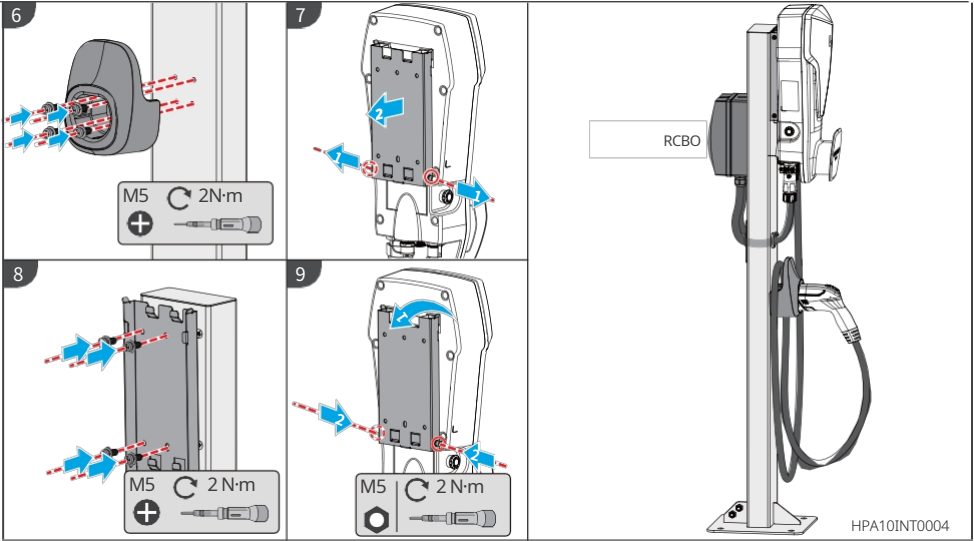

### 5.2.4 Installation of the MID meter (optional)

#### NOTICE

If you require a MID meter, please contact the manufacturer to purchase one.

GW7K-HCA-20

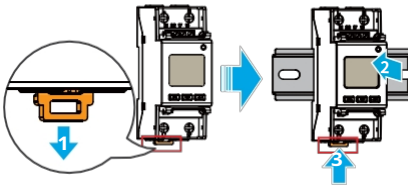

GW11K-HCA-20 and GW22K-HCA-20

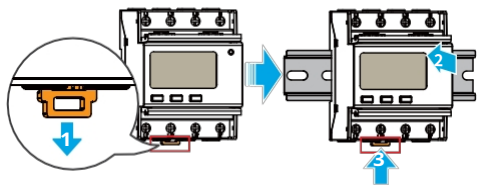

## 6 Electrical connection

### 6.1 Safety measures



#### DANGER

- All operations, cables and component specifications relating to electrical connections must comply with local laws and regulations.
- Before making electrical connections, switch off the power supply located in front of the device. Do not work with the power supply switched on. Failure to do so may result in electric shock.
- Bundle cables of the same type together and keep them separate from cables of different types. Do not place cables in a tangled or crossed position.
- If the cable is under too much tension, the connection may be poor. Leave a sufficient length of cable free before connecting it to the charger's cable port.
- When crimping the terminals, ensure that the conductive part of the cable is in full contact with the terminals. Do not crimp the cable sheath with the terminal. If this occurs, an unreliable connection could cause the charger to malfunction or damage the terminal block due to overheating or other phenomena.



#### WARNING

- Connect the supply cables correctly to the appropriate terminals, such as 'L1', 'L2', 'L3', "N" and "PE". Failure to do so will damage the charger.
- Ensure that the entire cable cores are inserted into the terminal holes. No part of the cable core must be exposed.
- Ensure that the cables are securely connected. Otherwise, the charger will be damaged due to overheating.

#### WARNING

- When making electrical connections, use personal protective equipment such as safety footwear, protective gloves and insulated gloves.
- All electrical connections should be carried out by qualified professionals.
- The cable colours shown in this document are for guidance only. Cable specifications must comply with local laws and regulations.
- Aluminium conductors and solid copper conductors are not recommended to facilitate cabling.

**Wiring specifications**

Model	Cable	Specifications
GW7K-HCA-20	Multi-strand three-core outdoor AC cable	<ul style="list-style-type: none"> <li>• Copper, 105 °C, 1000 V</li> <li>• Outer diameter: 13–14 mm</li> <li>• Conductor cross-sectional area: 6 mm<sup>2</sup></li> </ul>
GW11K-HCA-20	Multi-core five-core outdoor AC cable	<ul style="list-style-type: none"> <li>• Copper, 105 °C, 1000 V</li> <li>• Outer diameter: 12.6–17.3 mm</li> <li>• Conductor cross-sectional area: 4–6 mm<sup>2</sup></li> </ul>
GW22K-HCA-20		<ul style="list-style-type: none"> <li>• Copper, 105 °C, 1000 V</li> <li>• Outer diameter: 16.3–17.3 mm</li> <li>• Conductor cross-sectional area: 6 mm<sup>2</sup></li> </ul>

**RCBO specifications**

Model Charger	Type RCBO	Instantaneous tripping characteristic of the RCBO	RCBO Trip current	RCBO Rated current	RCBO Rated voltage
GW7K-HCA-20	TYPE A	C	30 mA	40 A	AC 230 V (2P)
GW11K-HCA-20				25 A	AC 400 V (4P)
GW22K-HCA-20				40 A	AC 400 V (4P)

## 6.2 nd RCD cable connection

### NOTICE

- The installation instructions below apply to devices purchased from the charger manufacturer. If the device is from a different supplier, you must use the relevant user manual.
- Power cable (AC) 1 connects to the mains or to the AC output of the inverter, and power cable (AC) 2 connects to the AC input of the charger.

**Step 1** Prepare the power cable (AC).

**Step 2** Feed the AC cable and terminal through the distribution box, and screw the AC terminal onto the RCBO.

**Step 3** Install the top cover of the RCBO distribution box to prevent the ingress of water or foreign objects.

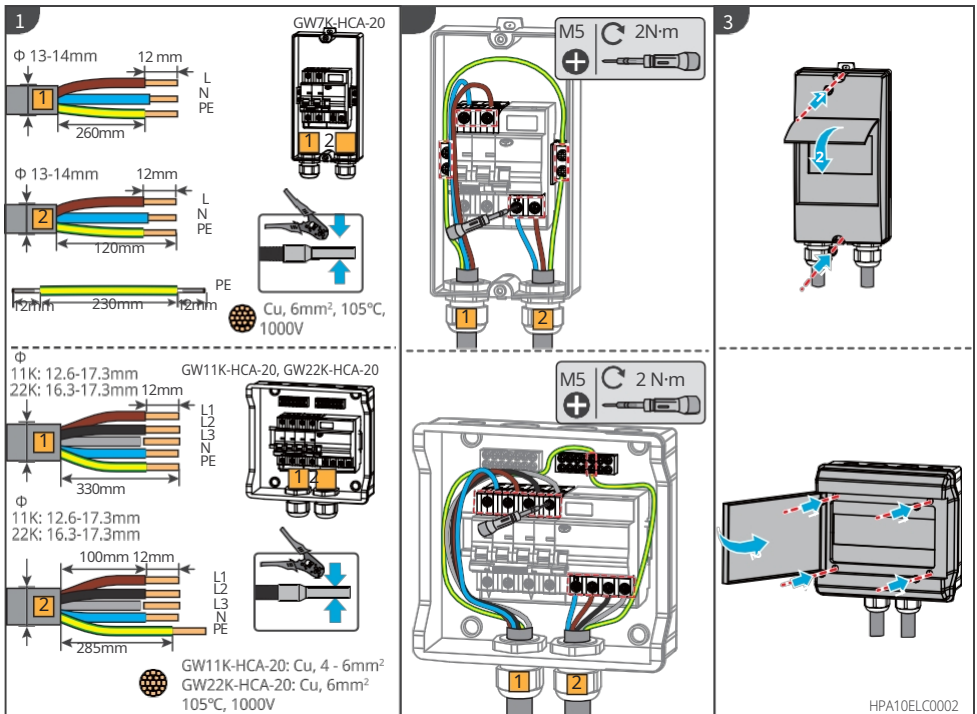



### 6.3 Connecting the power cable (- current)



Connect a single-phase input cable (AC) to the GW7K-HCA-20 charger; connect a three-phase input cable (AC) to the GW11K-HCA-20 and GW22K-HCA-20 chargers.

1. For the GW7K-HCA-20: the voltage must be 230 V AC, L/N/PE, the current must be 32 A and the frequency must be 50/60 Hz.
2. For the GW11K-HCA-20: the voltage must be 400 V AC, 3L/N/PE, the current must be 16 A and the frequency must be 50/60 Hz.
3. For GW22K-HCA-20: the voltage must be 400 V AC, 3L/N/PE, the current must be 32 A and the frequency must be 50/60 Hz.

The following figure shows a three-phase AC cable (L1, L2, L3, N, PE) as an example. Single-phase AC cables are L, N, PE.

**Step 1** Prepare the power cable (AC).

**Step 2** Insert the input cable (AC) into the terminals (AC) and tighten it.

**Step 3** Tighten the input terminal (AC) on the charger.

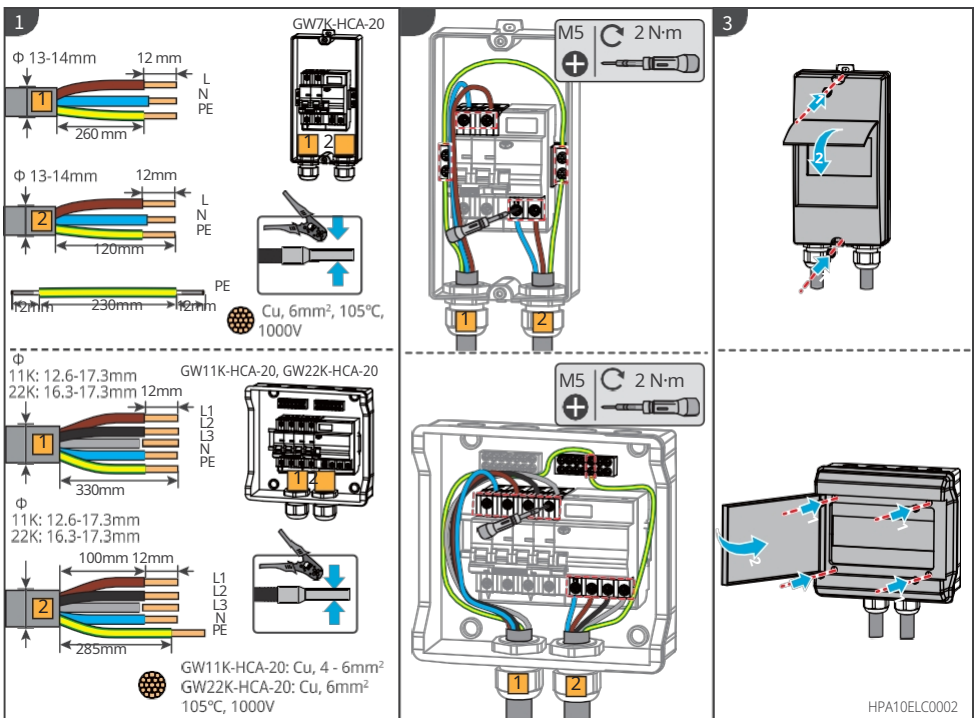

## 6.4 Connection of the communication cable

### WARNING

- When connecting the communication line, ensure that the port definitions of the cabling and the device fully match, and the cable routing should avoid sources of interference, power lines, etc., so as not to affect signal reception.
- Unused ports must be terminated to prevent any impact on the charger's protective performance.
- The charger's RS485\_A1/B1 ports are used for communication with the inverter. For the specific RS485 port on the inverter, please refer to the relevant inverter manual.
- After switching on the device, please check that the inverter connection status is displayed as a solid green light in the SolarGo app; otherwise, the inverter connection has failed.

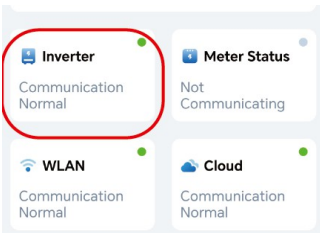

#### Type one

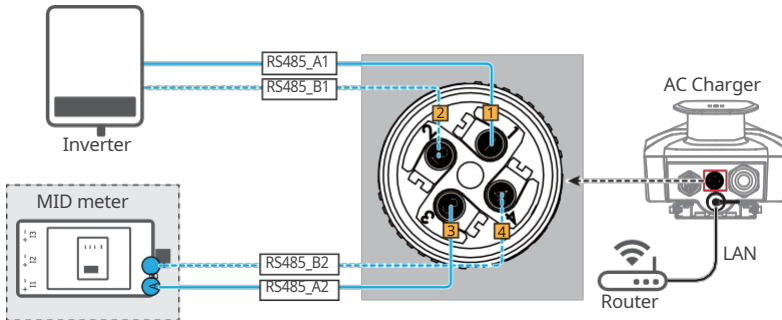

#### Type two

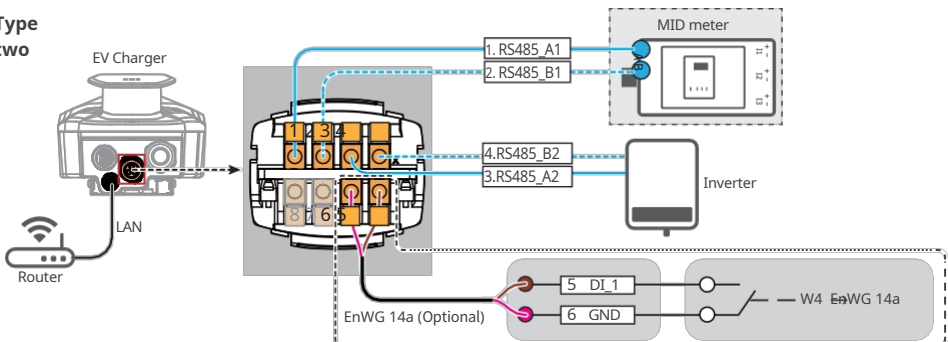

Converter type	Series / Power series	Model			ARM software version
On-grid inverter	SDT G2	GW5K-DT GW10KT-DT	GW6K-DT GW12KT-DT	GW8K-DT GW15KT-DT	59.183 or higher
	SDT G3	GW4000-SDT-30 GW6000-SDT-30 GW10K-SDT-30 GW12K-SDT-30 GW17K-SDT-30 GW12KLV-SDT-C30 GW23K-SDT-C30 GW27K-SDT-C30 GW25K-SDT-P31	GW5000-SDT-30 GW8000-SDT-30 GW10K-SDT-EU30 GW15K-SDT-30 GW20K-SDT-30 GW17KLV-SDT-C30 GW25K-SDT-C30 GW20K-SDT-31 GW30K-SDT-C30		05.56 or higher
		GW50K-SDT-C30			0.6 or higher
	GW5000-SDT-AU30 GW6000-SDT-AU30 GW8000-SDT-AU30 GW9990-SDT-AU30 GW15K-SDT-AU30 GW25K-SDT-AU30 GW25K-SDT-30	GW20K-SDT-AU30 GW29K9-SDT-AU30 GW30K-SDT-30		0.0 or higher	
Hybrid inverter	ET G1 (5–10 kW)	GW5K-ET GW10K-ET GW5KN-ET GW5KL-ET	GW6.5K-ET GW10KL-ET GW8KN-ET GW6KL-ET	GW8K-ET GW8KL-ET GW10KN-ET GW6.5KN-ET	30.290 or higher
	ET G2 (6–15 kW)	GW6000-ET-20 GW9900-ET-20 GW12K-ET-20	GW8000-ET-20 GW10K-ET-20 GW15K-ET-20		13,436 or higher
	ET (15–30 kW)	GW12KL-ET GW20K-ET GW25K-ET	GW15K-ET GW29.9K-ET	GW18KL-ET GW30K-ET	13,436 or higher
	ES G2 (3–6 kW)	GW3000-ES-20 GW5000-ES-20 GW3600M-ES-20 GW6000M-ES-20 GW3600-ES-BR20	GW3600-ES-20 GW6000-ES-20 GW5000M-ES-20 GW3500L-ES-BR20 GW6000-ES-BR20		10.427 or higher

### 6.4.1 RS485 communication cable connection

#### NOTICE

- Please provide your own outdoor twisted pair cable that complies with local standards.
- If the RS485 port is free, insert the supplied waterproof rubber plug into the connector and connect the connector to the charger.

**Step 1** Prepare the communication cable. **Step**

**2** Secure the cable to the connector. **Step 3**

Connect the connector to the charger.

#### Type one

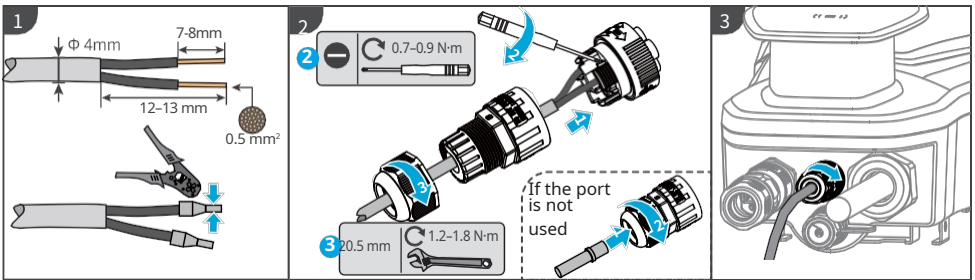

#### Type two

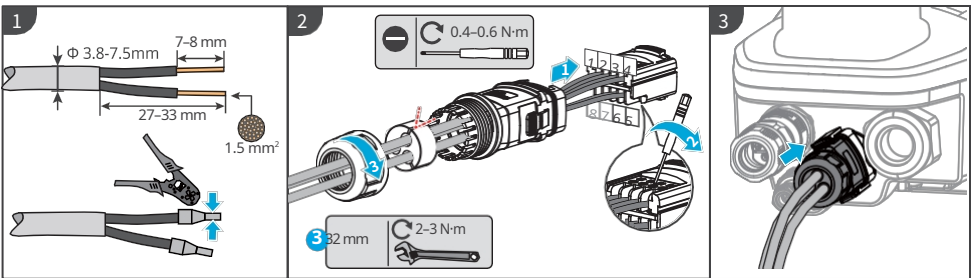

HCA20ELC007



### 6.4.2 Connecting the communication cable LAN

#### NOTICE

- You will need to provide the communication cable yourself.
- If the LAN-2 port is free, insert the connector with the supplied waterproof rubber plug and connect the connector to the charger.

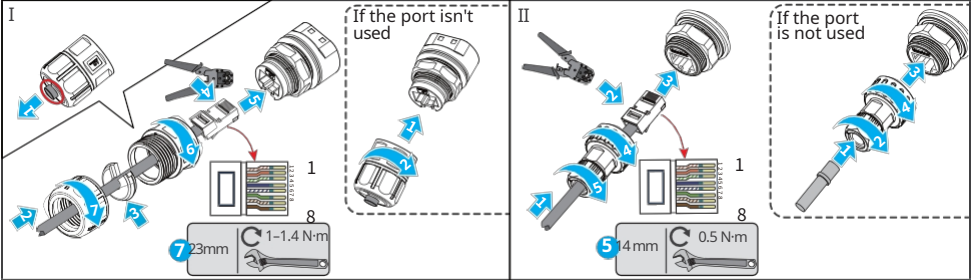

HPA10ELC004

### 6.4.3 Connection of the MID meter cable (optional)

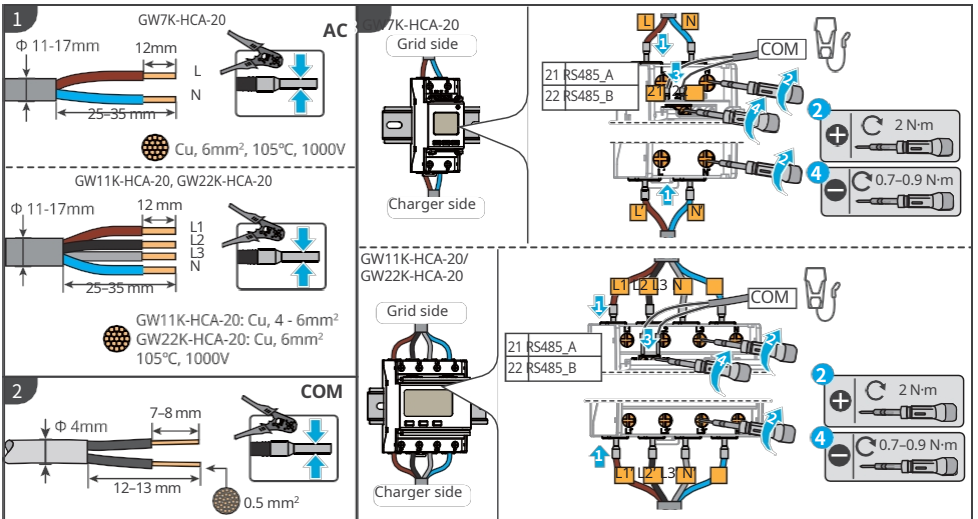

HCA20ELC005

## 7 Putting the device into operation

### 7.1 Checks to carry out before switching on the power supply

No.	Checkpoint
1	The charger is securely installed in a clean, well-ventilated and easily accessible location.
2	The DC input and communication cables are correctly and securely connected.
3	The cable harnesses are intact, correctly and neatly routed.
4	Unused ports and terminals are sealed.
5	Voltage, frequency and other network characteristics comply with the charger's operating requirements.

### 7.2 AC power supply

Connected to the mains

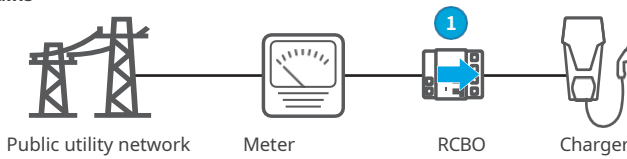

Switch on the RCBO between the charger and the mains.

Connected to the PV string and batteries

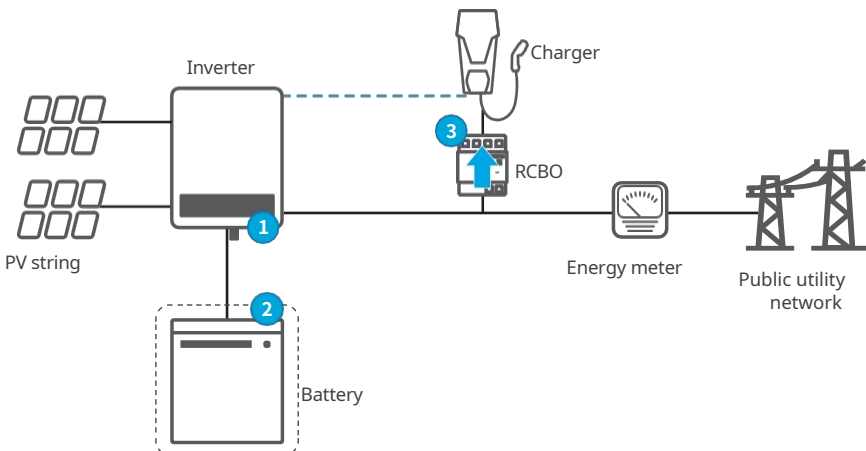

**Step 1** Switch on the AC and DC switches on the inverter side.

**Step 2 (optional)** Switch on the switches on the battery side.

**Step 3** Switch on the RCBO.



### 7.3 EV Charging

**! DANGER**

- Do not move the electric vehicle whilst charging.
- If an abnormal situation occurs during charging, press the emergency stop button to disconnect the power supply.
- Do not charge during thunderstorms or on rainy days. If charging is necessary, the charging plug and the EV charging port must be dry.
- Do not allow children to approach the charger. Children must not use the charger.
- It is prohibited to charge the EV if there is a fault or if the cable is damaged.

**WARNING**

- Before starting to charge, plug the charging plug into the EV charging port.
- Once charging is complete, disconnect the charging plug and replace the cover. Wind the cable around the dummy socket or the charger.
- If the EV does not support automatic charging, you must reconnect the charger's charging plug to resume charging if charging has been interrupted:
  - for AUTO Start mode, simply reconnect the charging plug and charging will restart;
  - for other modes, charging can be restarted by tapping the card or via the app.

#### 7.3.1 Starting charging via the SolarGo app or the SEMS Portal

SolarGo

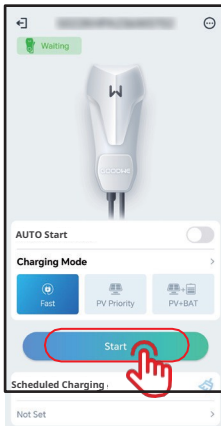

SEMS

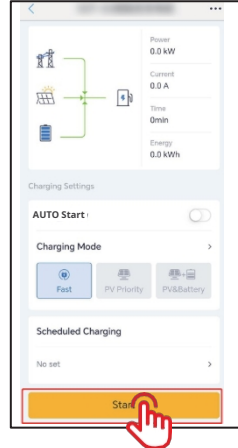

### 7.3.2 Planning charging via the SolarGo app or the SEMS portal

SolarGo:

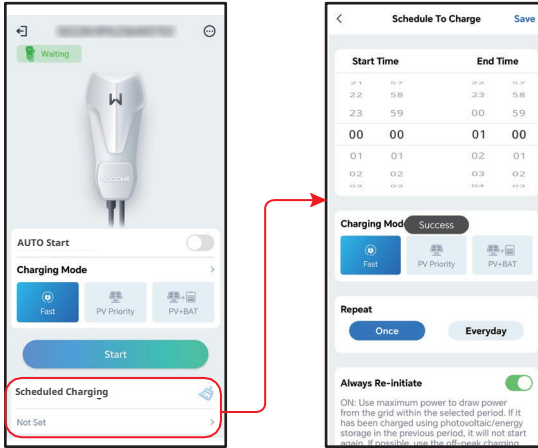

SEMS:

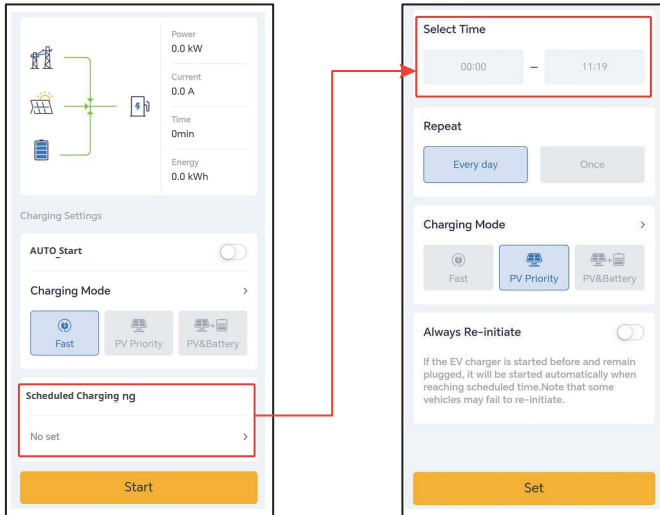

### 7.3.3 AUTO Mode Start

When AUTO Start mode is enabled, the car begins charging as soon as the charging cable is connected, without the need to tap an RFID card, unless scheduled charging is set.

SolarGo

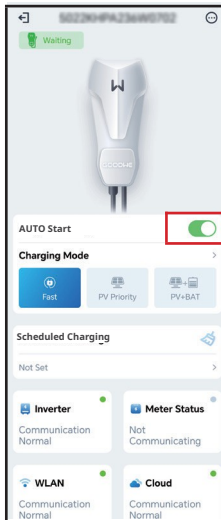

SEMS

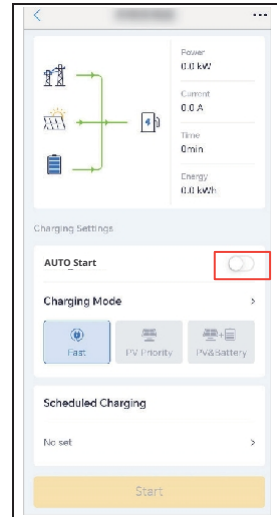

### 7.3.4 Charging RFID cards

#### NOTICE

- The RFID card must be paired with the charger beforehand. You can find the pairing procedure in section 8.2.6 or 8.3.6.
- The correct procedure is as follows: connect the charging plug to the electric vehicle and then tap the card.

Once you have tapped the card, the charger will start charging the electric vehicle.

# 8

## 8.1 Indicator

Indicator light	Colour	Explanation
	Green	The charger is in standby mode.
	Flashing green	The charger system is being updated.
	Blue light on	The charger is charging.
	Red light	A fault has occurred.
	The indicator light status when activating RFID card charging is abnormal	
	The red indicator light comes on for 2 seconds	Tap the card before connecting the charging plug to the electric vehicle.
	The red indicator light flashes twice	The charger and card do not match.

## 8.2 Setting up and checking charger information using the SolarGo app (for installers)

### 8.2.1 Downloading and installing the

Ensure that your mobile phone meets the following requirements:

- Mobile phone operating system: Android 4.3 or later, iOS 9.0 or later.
- The mobile phone has internet access.
- The mobile phone supports Wi-Fi or Bluetooth.

Method 1: Search for SolarGo on Google Play (Android) or the App Store (iOS), then download and install the app.











SolarGo app Method 2:

Scan the QR code below to download and install the app.



SolarGo App







SolarGo app



### NOTICE

This document is based on SolarGo version 6.5.0. The content may vary depending on the version of SolarGo.

## 8.2.2 Log in to the charger

### NOTICE

- Log in using the default password for the first time and change your password as soon as possible. To ensure the security of your account, we recommend changing your password regularly and remembering your new password.
- If the password is entered incorrectly three times, the account will be locked. To obtain a master password, please contact GOODWE after-sales service. After logging in, please change your login password.

**Step 1** Make sure the charger is switched on and working properly.

**Step 2** Select **Bluetooth** on the SolarGo app home screen.

**Step 3** Swipe down or tap **'Search Device'** to refresh the device list. Search for the device using the charger's serial number. Tap the device name to go to the **Home** screen.

**Step 4 (optional):** When you connect to the device via Bluetooth for the first time, a Bluetooth pairing prompt will appear; tap **'Pair'** to continue with the connection.

**Step 5** Enter the login password and go to the home page. Initial password: goodwe2022.

**Step 6 (optional):** If the default password is used, the app will prompt you to change the password after logging in. Change it or leave it as is, depending on your current needs.

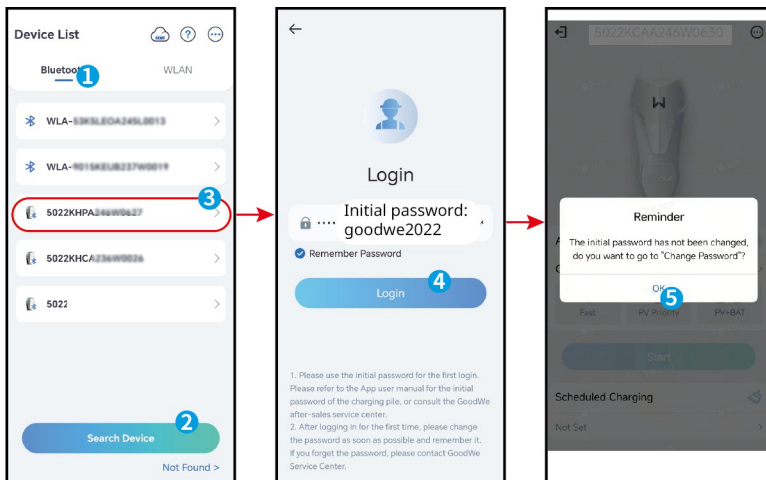

### 8.2.3 Introduction to the main page

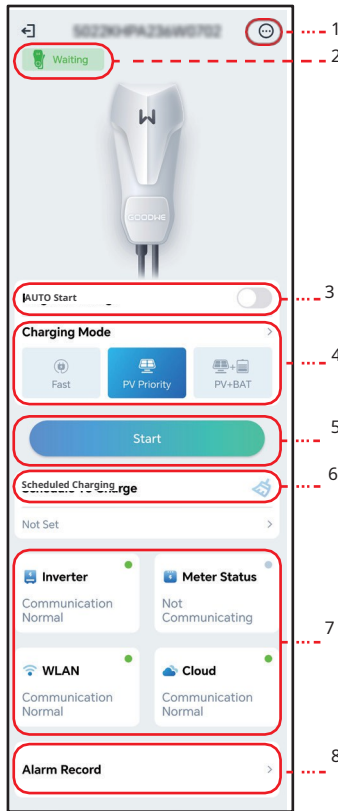

No.	Name/Icon	Description
1	More	Set the charger parameters. Such as <b>WiFi Configuration</b> , <b>Ensure Minimum Charging Power</b> , etc.
2	Device Status	Charger status, such as <b>Idle (plugged)</b> , <b>Charging</b> , etc.
3	AUTO Start	Once the charging plug is connected, start charging without tapping the card.
4	Charging Mode	Select the charging mode for the EV.
5	Start/End Charging	<ul style="list-style-type: none"> <li>Start charging: Begin charging the electric vehicle.</li> <li>End charging: Stop charging the electric vehicle.</li> </ul>
6	Scheduled Charging	Set the duration of a single charge or the duration of a charging cycle.
7	Communication Status	<b>Inverter</b> : whether the charger is communicating with the inverter. <b>Meter</b> : whether the charger is communicating with the meter. <b>WiFi</b> : whether the charger is communicating with the router. <b>Cloud</b> : whether the charger is communicating with the cloud.
8	Alarm Record	Check the alarms.



### 8.2.4 nd WiFi Configuration

Configure the router or switch that communicates with the charger to ensure communication between the charger and the router or switch. Otherwise, the charger cannot connect to the server.

**Step 1** Tap **More** > **Communication Setting** to configure the parameters.

**Step 2** Tap **Network Name** and select the correct network. Enter **the password for** the selected network.

**Step 3** Enable or disable **DHCP** as required.

**Step 4** Configure **the IP Address, Subnet Mask, Gateway Address** and **DNS Server** according to the router or switch information when **DHCP** is disabled.

**Step 5** Tap **Save** to complete the settings.

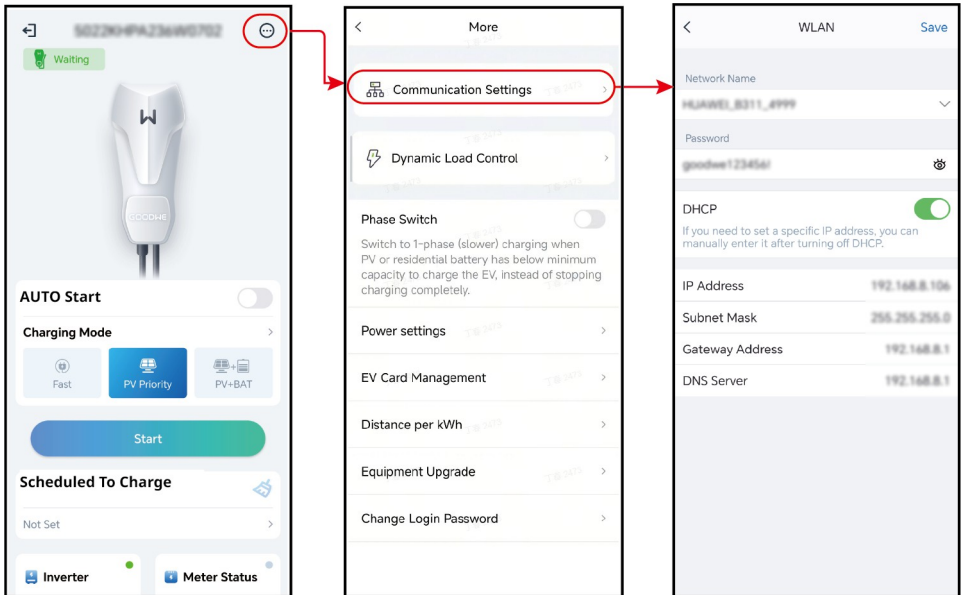

No.	Parameters	Description
1	Network Name	Select the network to establish communication between the charger and the router or network switch. The charger can then be connected to the cloud.
2	Password	The Wi-Fi password for the currently connected network.
3	DHCP	<ul style="list-style-type: none"> <li>Enable DHCP when the router is in dynamic IP mode.</li> <li>Disable DHCP when a switch is in use or the router is in static IP mode.</li> </ul>
4	IP Address	<ul style="list-style-type: none"> <li>Do not configure these settings when DHCP is enabled.</li> <li>Configure the parameters according to the router or switch information when DHCP is disabled.</li> </ul>
5	Subnet Mask	
6	Gateway Address	
7	DNS Server	

## 8.2.5 nd Charging Mode Configuration

There are three charging modes available: Fast, PV Priority and PV+Battery.

### Fast

The charger uses electricity from the mains, photovoltaic panels or batteries to charge electric vehicles. The charger's output power is set by default to the charger's rated output power, and users can set the output power to a value no higher than the rated output power.

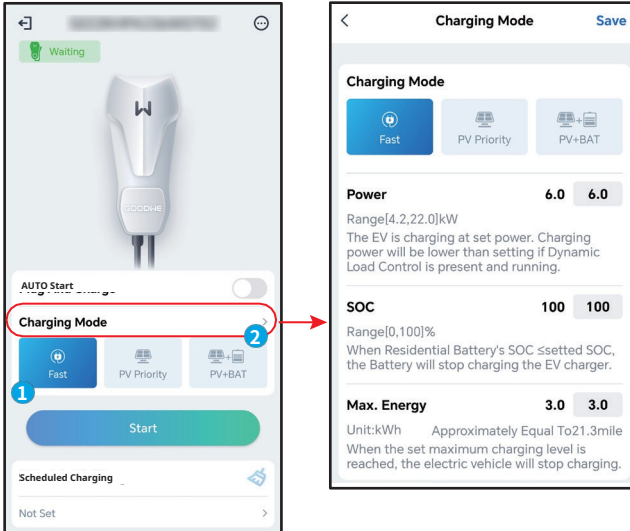



### PV priority

Only photovoltaic energy is used to charge the electric vehicle. Loads, which may be grid loads or backup loads, take priority when consuming energy from the photovoltaic system; the remaining energy will be used to charge the electric vehicle.

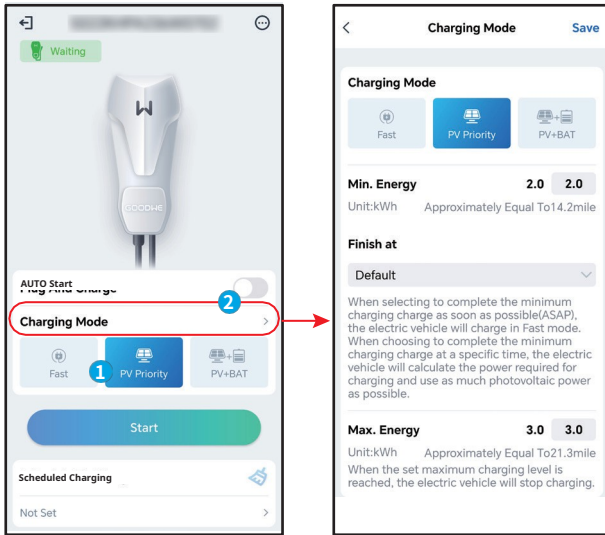

### PV + Battery

Photovoltaic energy and the battery are used to charge the electric vehicle. Load The load, which may be a grid load or a backup load, takes priority in energy consumption; any remaining energy will be used to charge the electric vehicle.

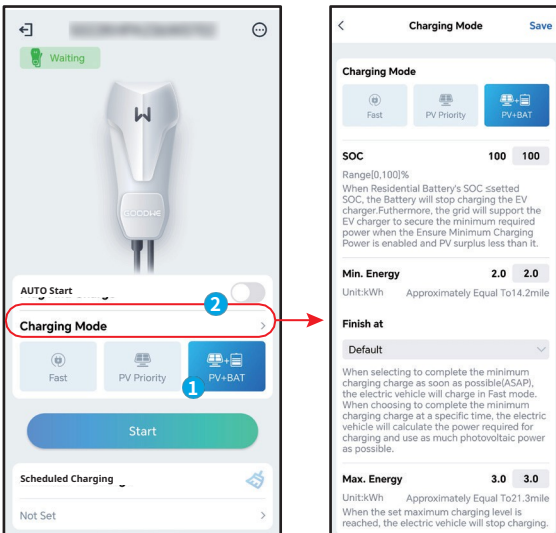

### 8.2.6 Next

#### Dynamic Load Control

Once dynamic load control is enabled, the charger will adjust the charging rate (or even pause charging) based on data from the meter and the set mains connection current to prevent the main fuse from tripping. If the actual current drawn approaches the set mains connection current, the charger will reduce the charging power and interrupt charging to prevent a trip. The charger will automatically restart once the difference between the set mains connection current and the current drawn from the mains meets the charger's start-up conditions.

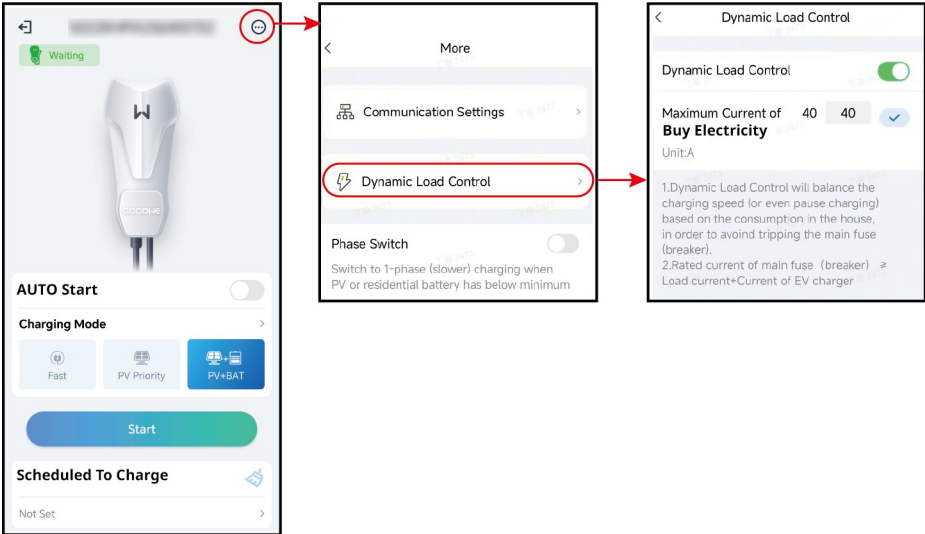



**Phase switch**

WARNING	
The phase switching function is only available for three-phase chargers.	

Status	Explanation
On	If the total power consumption is less than 4.2 kW, the charger automatically switches to single-phase charging mode to prevent purchasing energy from the grid or the charger switching off. The minimum charging power in single-phase charging mode is 1.4 kW. (The phase switching time is approximately 3 minutes)
OFF	The charger remains in three-phase charging mode.

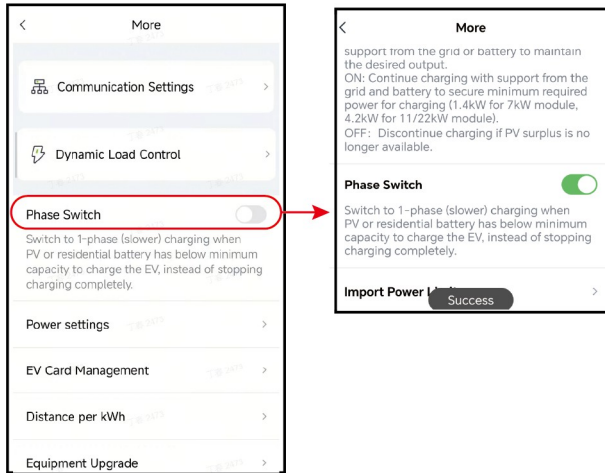

## Power settings

Step: Click on More > Power settings and set the relevant parameters.

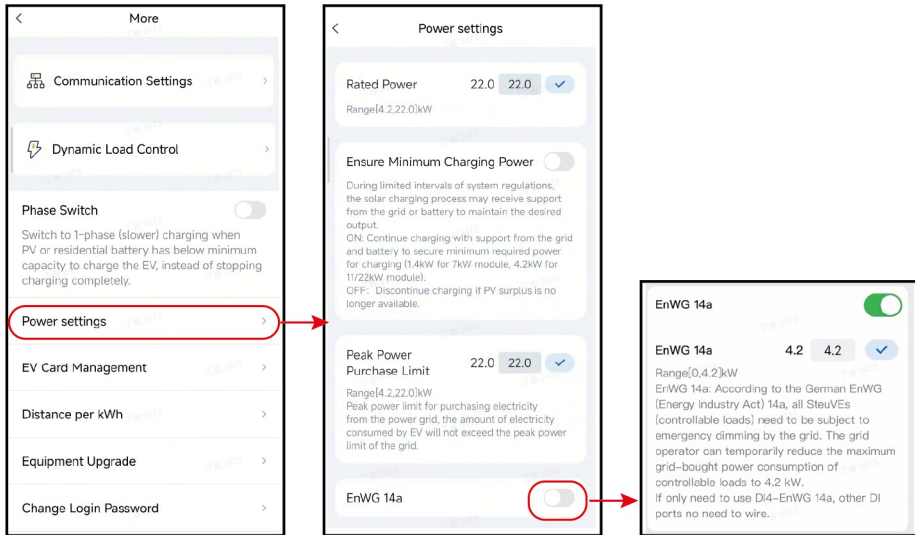

No.	Specifications	Descriptions
1	Design power	Set the charger's charging power. If not set, the default charging power is the rated power.
2	Ensure minimum charging power	'During limited intervals of system regulation, the solar charging process may accept support from the grid or battery to maintain the required power. ON: Continue charging with support from the grid and battery to ensure the minimum required charging power (1.4 kW for a 7 kW module, 4.2 kW for an 11/22 kW module). OFF: Stop charging if surplus PV power is no longer available.
3	Maximum power	Maximum power limit for purchasing electricity from the grid; the amount of electricity consumed by the EV will not exceed the grid's maximum power limit.
4	EnWG 14a	Under the German EnWG (Energy Industry Act) 14a, all SteuVEs (controllable loads) must be subject to emergency load shedding by the grid. The grid operator may temporarily reduce the maximum power consumption purchased from the grid for controllable loads to 4.2 kW. If you only need to use DI4 – EnWG 14a, the other DI ports do not need to be connected.



## EV Card Management

RFID cards can be added and removed, and each charger can hold up to 10 cards.

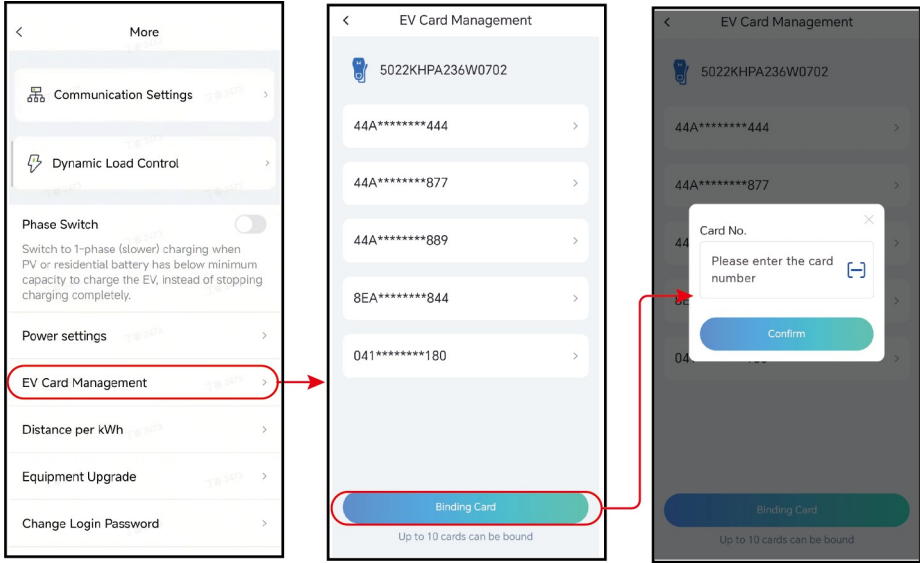

## Distance per kWh

You can set the conversion ratio between energy and kilometres or leave the default setting.

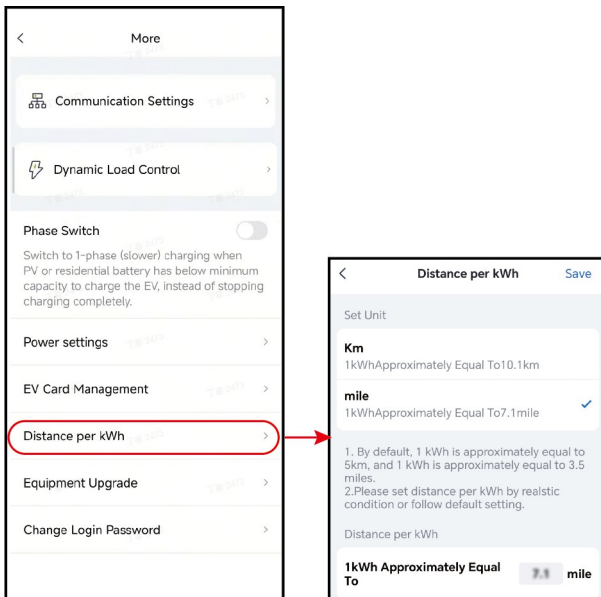

**Device update**

**Step:** Click More > Device Update to update the EV charger.

**Change login password**

**Step:** Click More > Change login password to change your password.

**Restore factory settings****WARNING**

After restoring factory settings, the password will revert to the original password goodwe2022.

**Step:** Click More > Restore factory settings.



## 8.3 Setting up and checking charger information via the SEMS Portal APP (installers)

### 8.3.1 Downloading and installing the SEMS Portal APP

**Mobile phone requirements:**

- Operating system: Android 4.3 or higher; iOS 9.0 or higher.
- Capable of connecting to the internet and browsing online.
- Support for WLAN/Bluetooth connectivity.

Method 1 Search for the SEMS portal on Google Play (Android) or the App Store (iOS), then download and install;



Method 2 Scan the QR code below to download and install.



### 8.3.2 End- nd user account registration

Tap **Register** and fill in the fields to register.

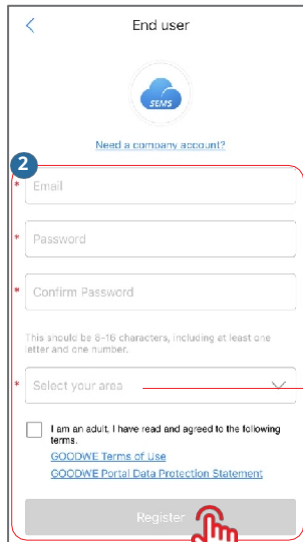
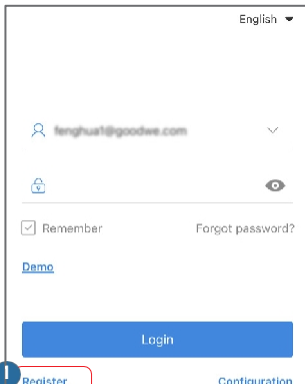

Note: Select **your region** based on where you are located. Incorrect selection may result in the device not being created successfully.

### 8.3.3 Logging into the application

#### NOTICE

You have already received your account and password.

Enter your username and password, click **Login** and access the SEMS Portal application.

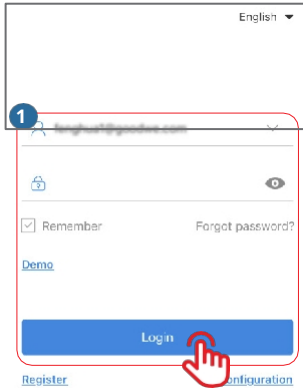

SEMS PORTAL V3.3.17

APPs >

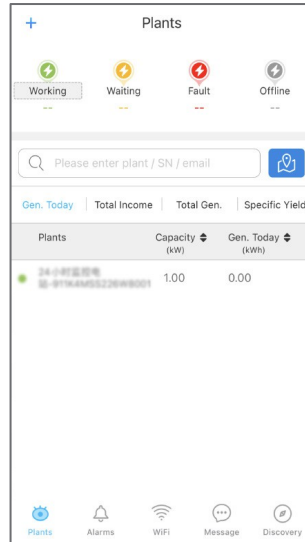



### 8.3.4 nd Device Creation

Step 1 Follow the steps below to access the **Create Plant** page.

Step 2 Read the instructions, enter the required details and tap the **Submit** button. (\* indicates mandatory fields)

Step 3 Follow the instructions to add the device and complete the creation process. (Or tap the **ADD** button on the main page to add new devices.)

The screenshots show the following steps:

- Home Screen:** A red box highlights the '+' icon in the top left corner.
- Main Menu:** A red box highlights the 'Create Plant' icon.
- Create Plant Form:** A red box highlights the 'Submit' button at the bottom. The form includes fields for Owner's Email, Plant Name (with a red asterisk), Address, Classification (Residential), Capacity (with a red asterisk), Module (Amount of solar panels), Profit Ratio (with a red asterisk), and an Upload Photos section.
- Scan QR code:** A red box highlights the 'Add Device' button at the bottom. The screen prompts to scan the device's QR code and includes fields for SN, CheckCode, and Name.
- Add device selection:** A red box highlights the '+ADD' button in the top right, and another red box highlights the 'Micro Inverter' option in the list. Other options include Inverter, DataLogger, and EV Charger. A 'Cancel' button is at the bottom.

### 8.3.5 nd charging mode configuration

There are three charging modes available: Fast, PV priority and PV+battery.

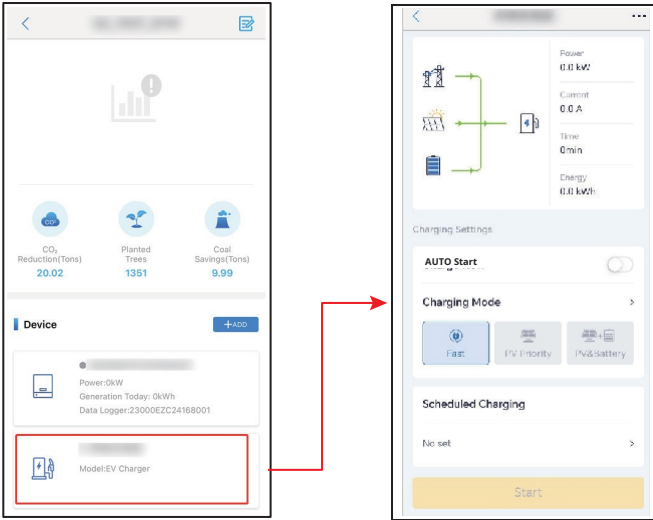

#### Fast

The charger uses electricity from the mains, solar panels or batteries to charge electric vehicles. The charger's output power is set by default to the charger's rated output power, and users can adjust the output power according to their current needs (not exceeding the rated output power).

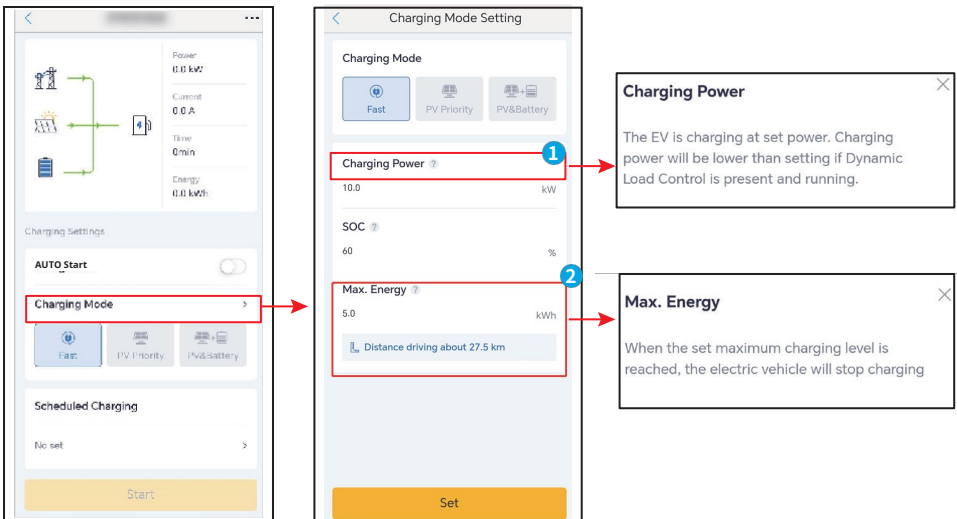



### PV priority

Only photovoltaic energy is used to charge the electric vehicle. The load takes priority when consuming energy from the photovoltaic system; the remaining energy will be used to charge the electric vehicle.

The image shows two screenshots of a mobile application interface. The left screenshot shows the main 'Charging Settings' screen with 'PV Priority' selected under 'Charging Mode'. The right screenshot shows the 'Charging Mode Setting' screen with 'PV Priority' selected. Two callout boxes provide details for 'Min. Top Up' and 'Max. Energy'.

**Min. Top Up**

Minimum amount of charge that the EV needs to get. Depending on the finish time, the power can be supplied from the grid if there is no sufficient PV production, or enough capacity in the residential battery.

**Max. Energy**

When the set maximum charging level is reached, the electric vehicle will stop charging

### PV + Battery

Photovoltaic energy and the battery are used to charge the electric vehicle. The load takes priority in energy consumption; any remaining energy will be used to charge the electric vehicle.

The image shows a two-step process for setting the charging mode to 'PV+Battery'. The first screenshot shows the main 'Charging Settings' screen where 'Charging Mode' is highlighted. The second screenshot shows the 'Charging Mode Setting' screen with three callouts: 1. 'SOC' (State of Charge) set to 60%, 2. 'Min. Top Up' set to 5.0 kWh, and 3. 'Max. Energy' set to 5.0 kWh. Each callout includes a brief explanation of the setting's function.

**SOC**

The Residential battery will be used to charge the EV until it reaches set percentage. When the SOC is equal to, or lower than, set percentage, the battery will not be used to charge the EV.

**Min. Top Up**

Minimum amount of charge that the EV needs to get. Depending on the finish time, the power can be supplied from the grid if there is no sufficient PV production, or enough capacity in the residential battery.

**Max. Energy**

When the set maximum charging level is reached, the electric vehicle will stop charging



### 8.3.6 Settings

#### Dynamic load control

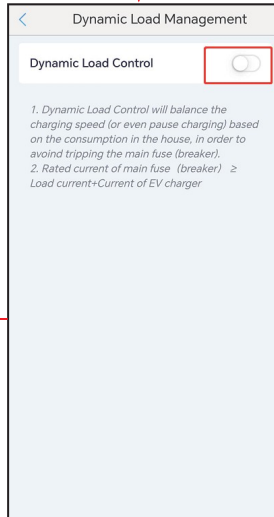
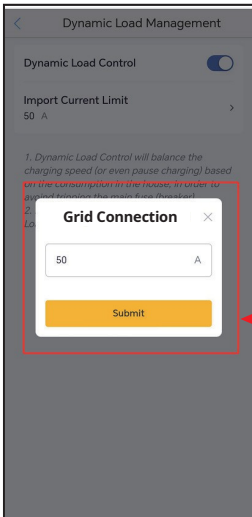
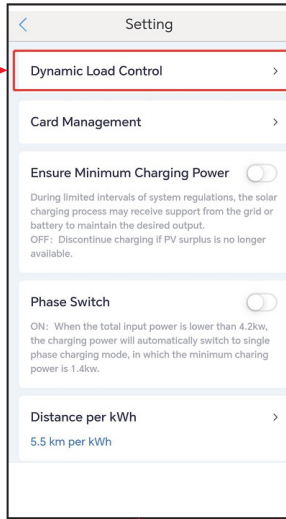
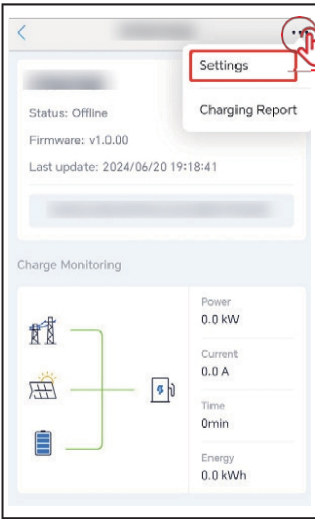

## Ensuring minimum charging power

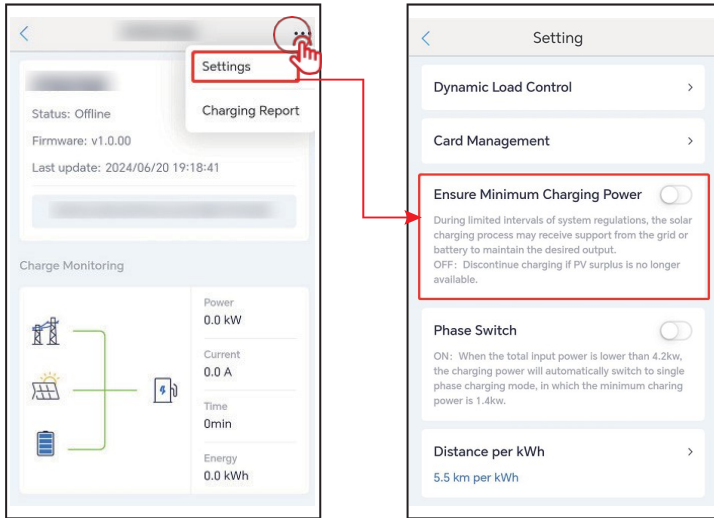



### RFID Card Management

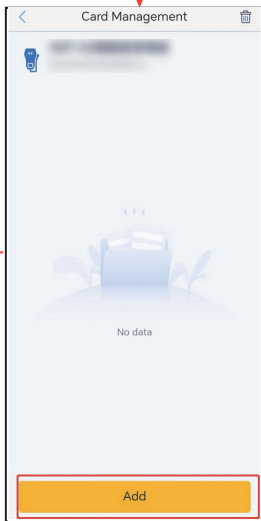
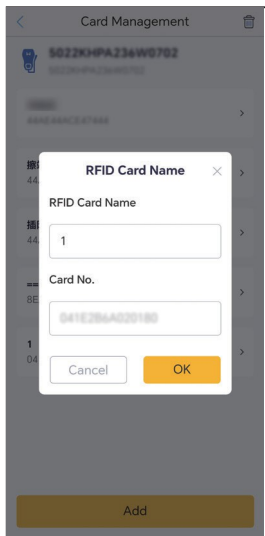
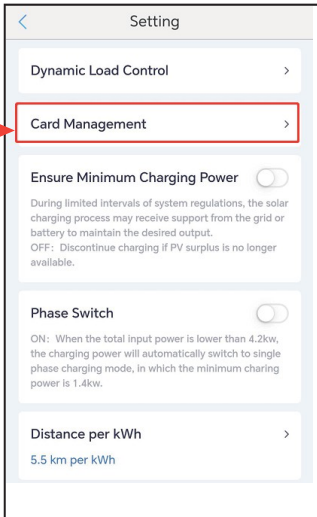
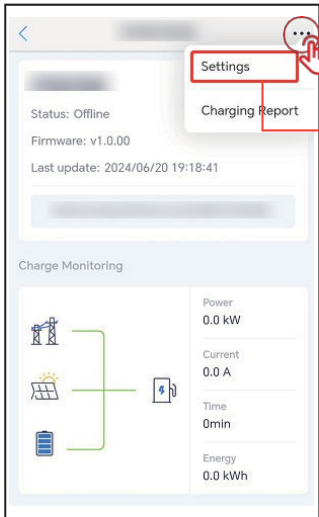

## Phase switch

### NOTICE

The phase switching function is only available for three-phase chargers.

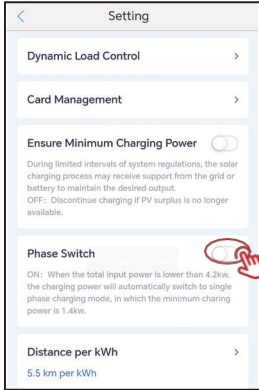

## Distance per kWh

You can set the conversion ratio between energy and kilometres or leave the default setting.

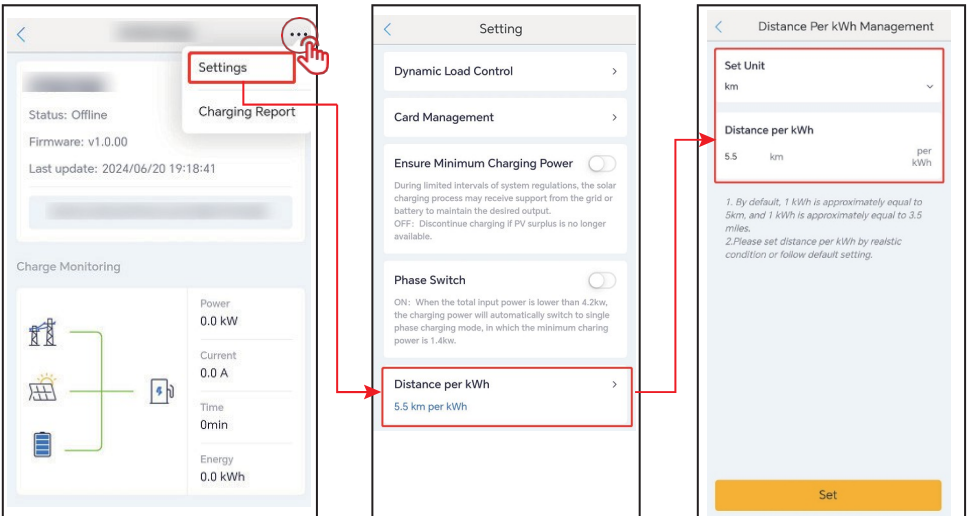



## 9 Maintenance

### 9.1 Turning off the charger's



Switch off the charger before carrying out any operation or maintenance. Failure to do so may result in damage to the charger or an electric shock.

Disconnect the RCD between the charger and the mains/inverter.

### 9.2 Disassembling the charger



- Ensure that the charger is switched off.
- Wear appropriate personal protective equipment before carrying out any operations.

**Step 1** Disconnect all cables, including power and communication cables.

**Step 2** Remove the charger from the mounting plate.

**Step 3** Remove the mounting plate.

**Step 4** Store the charger properly. If you need to use the charger later, ensure that the storage conditions meet the requirements.

### 9.3 Disposal of the charger

If the charger is no longer functional, dispose of it in accordance with local regulations for the disposal of electrical equipment. The charger must not be disposed of with household waste.

### 9.4 's routine maintenance

Maintenance item	Maintenance method	Maintenance interval
Emergency stop button	Press the EMS button on and off three times in succession to ensure it is working correctly.	Once every 6 months
Electrical connection	Check that the cables are securely connected. Check that the cables are not broken and that the copper core is not exposed.	Once every 6–12 months
Seals	Check that all terminals and ports are properly sealed. Re-seal the cable entry if it is not sealed or is too large.	Once every 6–12 months

## 9.5 Troubleshooting

If a fault occurs, the charger will start flashing red. Log in to the SEMS Portal or the PV Master app for detailed troubleshooting.

Follow the troubleshooting methods below. If these methods do not work, contact after-sales service.

Before contacting after-sales service, please have the information listed below ready so that issues can be resolved quickly.

1. Information about the charger, such as the serial number, software version, installation date, time of failure, frequency of failures, etc.
2. Installation environment, including weather conditions and similar factors. It is recommended to provide photographs and videos to assist with analysing the problem.
3. The situation in the power supply network.

No.	Fault	Cause	Solution
1	Failure to connect the gun	The charger was disconnected during charging.	Reconnect the charger.
2	Emergency stop	The emergency stop button has been pressed.	Release the button.
3	Earthing fault	The AC input earthing cable has been disconnected.	Check the earthing cable and reconnect it.
4	Ambient temperature	The charger temperature is higher than 98 degrees.	The problem will be resolved once it has cooled down and the charger will switch to standby mode.
5	Overvoltage	An overvoltage has been detected at the AC input.	The problem will be resolved once normal voltage is restored, and the charger will switch to standby mode.
6	Live	An undervoltage has been detected at the AC input.	
7	Overcurrent	A short circuit or an overcurrent has occurred.	The problem will be resolved as soon as normal current is restored, and the charger will switch to standby mode.



No.	Fault	Cause	Solution
8	Deviation time limit	<ol style="list-style-type: none"> <li>1. The EV battery is fully charged.</li> <li>2. The ambient temperature is too low and the battery cannot be charged.</li> <li>3. The charger connection is faulty.</li> </ol>	<ol style="list-style-type: none"> <li>1. Use the software to check whether the battery has finished charging.</li> <li>2. If the environment is too cold, start the electric vehicle to preheat it for about 5 minutes before charging.</li> <li>3. Check and disconnect the charging connector, then reconnect it after about 15 seconds.</li> </ol>
9	Setting the time limit	Communication via the CP signal was unsuccessful.	<ol style="list-style-type: none"> <li>1. Check that the EV is fully charged.</li> <li>2. After disconnecting the charging connector for approximately 15 seconds, reconnect it; if the problem persists, contact your dealer or after-sales service. If the problem still persists, contact your dealer or after-sales service.</li> </ol>
10	Fault in the welded contactor	An internal component has failed.	Switch the charger off and on again. If the problem cannot be resolved, contact your dealer or after-sales service.
11	Meter failure		
12	Leakage current fault		
13	Reading error		
14	EEPROM error		
15	Flash error		
16	Leakage detector failure		

## 10 Technical specifications

Technical data	GW7K-HCA-20	GW11K-HCA-20	GW22K-HCA-20
Input			
Rated input voltage (V)	230 <sup>±3</sup> , L/N/PE	400 <sup>±3</sup> , 3L/N/PE	400 <sup>±3</sup> , 3L/N/PE
Rated input current (A)	32	16	32
Nominal AC mains frequency (Hz)	50/60	50/60	50/60
Output			
Rated output power (W)	7000	11,000	22,000
Rated output voltage (V)	230	400	400
Rated output current (A)	32	16	32
Nominal output frequency (Hz)	50/60	50/60	50/60
Protection			
Residual current residual current	AC 30mA + DC 6mA	AC 30mA + DC 6mA	AC 30mA+ DC 6mA
Overcurrent protection	Integrated	Integrated	Integrated
Overcurrent protection	Integrated	Integrated	Integrated
Overheating protection overheating	Integrated	Integrated	Integrated
Protection against earth fault	Integrated	Integrated	Integrated
AC surge protection	Type III	Type III	Type III
Emergency shutdown	Type III	Type III	Type III
General data			
Operating temperature range (°C)	-30 ~ +50 <sup>*1</sup>	-30 ~ +50 <sup>*1</sup>	-30 ~ +50 <sup>*1</sup>



Technical Specifications	GW7K-HCA-20	GW11K-HCA-20	GW22K-HCA-20	
Relative humidity	5% ~ 95% (Non-condensing)	5% ~ 95% (Non-condensing)	5% ~ 95% (Non-condensing)	
Max. operating altitude (m)	2000	2000	2000	
Cooling method	Natural convection	Natural convection	Natural convection	
User interface	Wi-Fi + app, LED	WLAN+APP, LED	Wi-Fi + App, LED	
Start method	APP, RFID, AUTO Start	APP, RFID, AUTO Start	APP, RFID, AUTO Start	
Communication	Bluetooth, WiFi, RS485 (*2), LAN	Bluetooth, WiFi, RS485 (*2), LAN	Bluetooth, WiFi, RS485 (*2), LAN	
Operating mode	Fast charging PV priority PV+BATT Scheduled charging Dynamic load control	Fast charging PV priority PV+BATT Scheduled charging Dynamic load control	Fast charging PV priority PV+BATT Scheduled charging Dynamic load control	
Weight (kg)	5.2 (with 6 m cable) 5.6 (with 7.5 m cable)	5.4 (with 6m cable) 5.6 (with 7.5m cable)	6.4 (with 6m cable) 7.1 (with 7.5 m cable)	
Dimensions (W×H×D) (mm)	208×450×170		208×450×170	208×450×170

Noise emission (dB)	< 20	< 20	< 20
Noise emission (dB)	< 6.5	< 6.5	< 6.5
Ingress protection rating	IP66*2	IP66*2	IP66*2
Output cable and connector	6 m cable (7.5 m optional) IEC Type 2	6m cable (7.5m optional)	6m cable (7.5m optional)
Accessories	RFID Card*2	IEC Type 2	IEC Type 2
Installation	Indoors or outdoors	Indoors or outdoors	Indoors or outdoors
Communication protocol	Modbus TCP	Modbus TCP	Modbus TCP
Protection	An external Type A residual current device is required	An external Type A residual current device is required	An external Type A residual current device is required
MTBF (hours)	100,000	100,000	100,000
Protection class	I	I	I
Mounting method	Wall/floor (optional stand)	Wall/floor (optional stand)	Wall/floor (optional stand)
Certifications	IEC 61851-1 IEC 62311 IEC 62955 AS/NZS 4268:2017 IEC 61008-1	IEC 61851-1 IEC 62311 IEC 62955 AS/NZS 4268:2017 IEC 61008-1	IEC 61851-1 IEC 62311 IEC 62955 AS/NZS 4268:2017 IEC 61008-1
EMC	Class B	Class B	Class B
Country of manufacture	China	China	China

\*1: Operating temperature range (°C): The charger is -30~+55°C and the charging plug is 50°C

\*2: Ingress protection rating: The IEC Type 2 charging plug is IP55

\*3: For Brazil: 220/380/380 V AC



GoodWe website

## GoodWe Technologies Co., Ltd.

~~No. 90 Zijin Rd., New District, Suzhou, 215011, China~~

 [www.goodwe.com](http://www.goodwe.com)

 [service@goodwe.com](mailto:service@goodwe.com)

